

**ISTRUZIONI DI POSA**

**ASSEMBLY INSTRUCTIONS**

**INSTRUCTIONS DE MONTAGE**

**MONTAGEANLEITUNG**

**INSTRUCCIONES PARA LA COLOCACION**

## **Remarque importante:**

Ne pas utiliser l'escalier avant qu'il ne soit complètement assemblé!

Il est nécessaire que tous les composants ainsi que le garde-corps soient installés avant que vous ne montiez sur les marches.

Le matériel de montage doit être adapté à vos conditions locales et acheté séparément. Veuillez vous assurer que les produits sont montés de manière sûre, solide et stable. Nous ne sommes pas responsables des dommages causés par une installation ou une utilisation incorrecte.

**CALCOLO DELL'ALZATA (A) / CALCULATION OF THE RISE (A) / CÁLCULO DE LA CONTRAHUELLA (A) / CALCUL DE LA CONTREMARCHE (A) / BERECHNUNG DER STEIGUNG (A)**

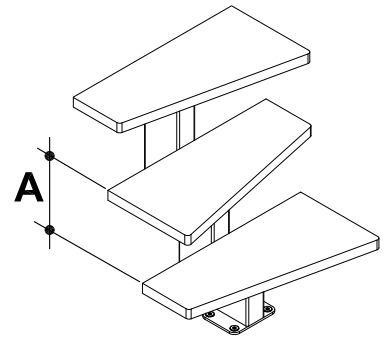
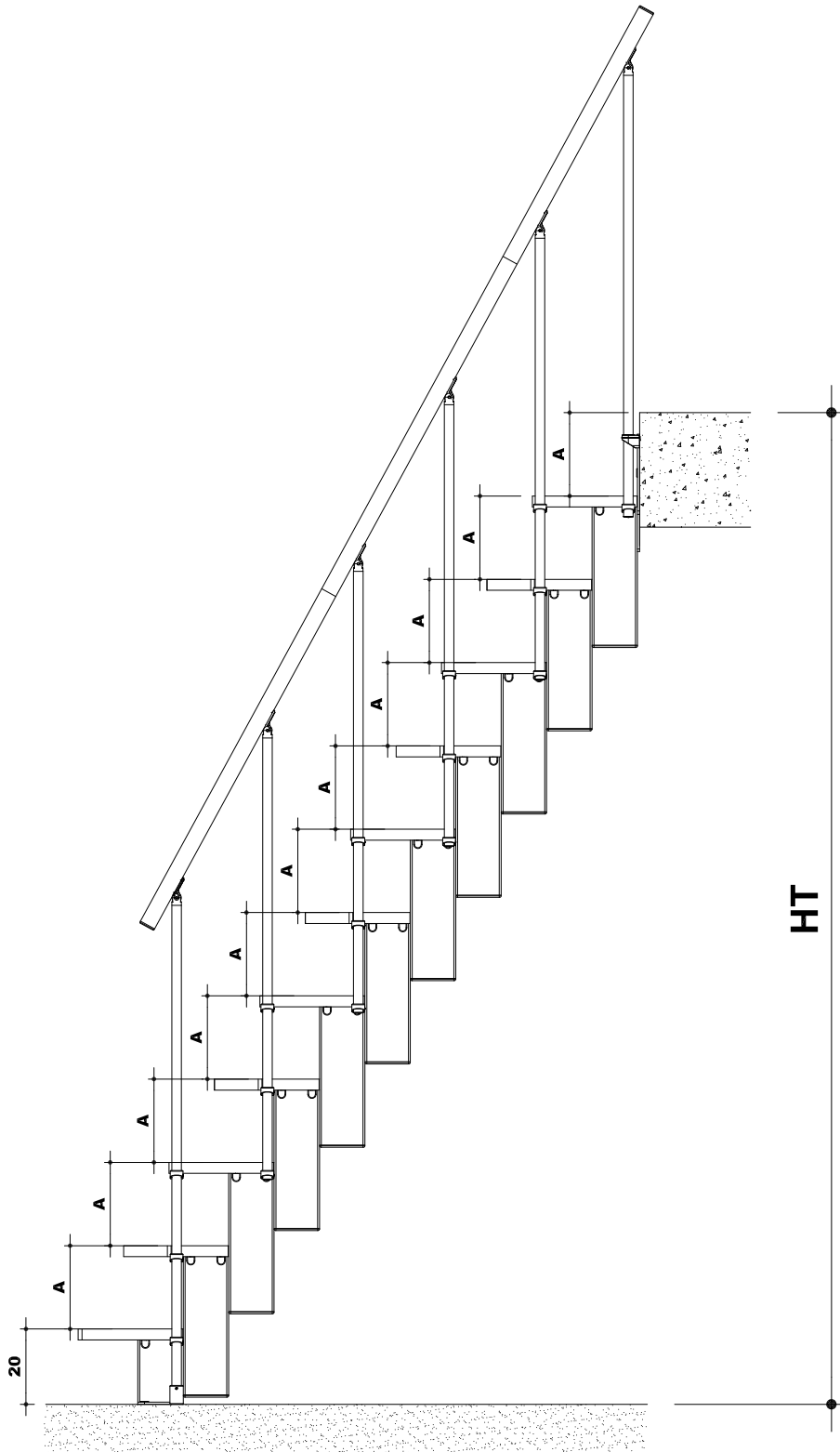

$$20 \leq A \leq 24$$

$$A = (HT - 20) : n$$

- n = numero di gradini
- n = number of steps
- n = número de peldaños
- n = nombre de marches
- n = Anzahl Stufen

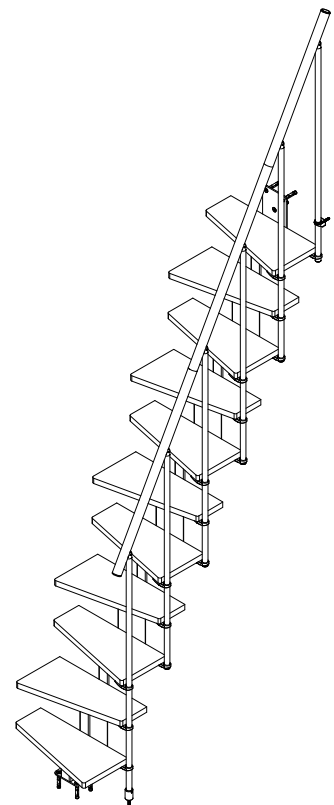
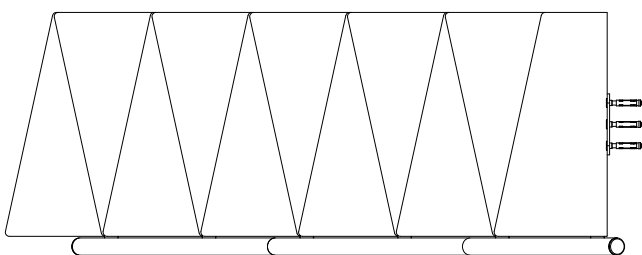

VERIFICA MISURE DEL VANO / VERIFY THE MEASURES OF THE SPACE / COMPROBAR LA MEDIDA DEL ESPACIO /  
 VÉRIFIER LES DIMENSIONS DE LA TRÉMIE / ÜBERPRÜFEN SIE DIE ABMESSUNGEN DES TREPPENAUGES

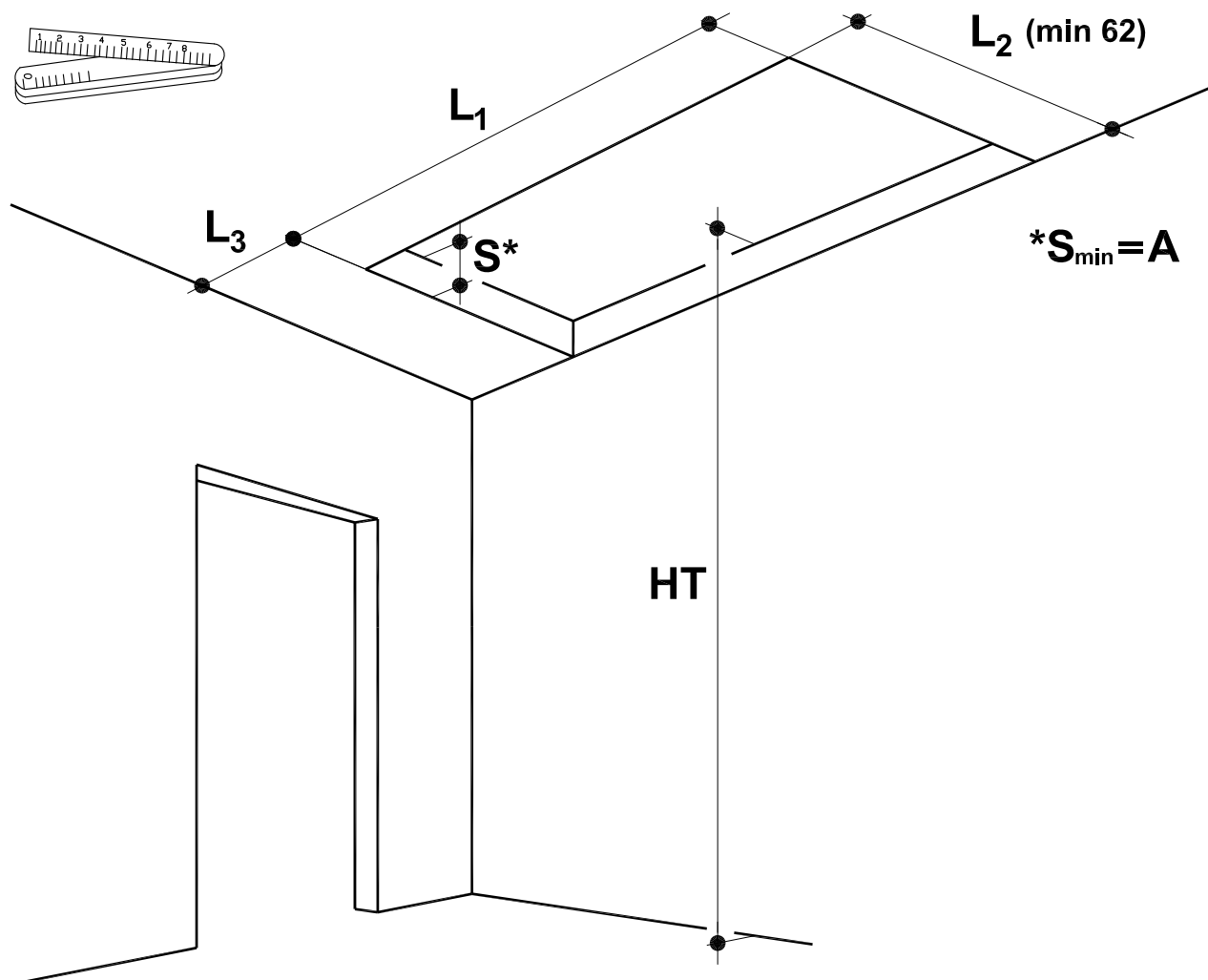

| HT                       | $220 \leq HT \leq 260$ | $240 \leq HT \leq 284$ | $260 \leq HT \leq 308$ | $280 \leq HT \leq 332$ | $300 \leq HT \leq 356$ |
|--------------------------|------------------------|------------------------|------------------------|------------------------|------------------------|
| <b>n</b>                 | 10                     | 11                     | 12                     | 13                     | 14                     |
| <b>Y</b>                 | 137                    | 149                    | 161                    | 173                    | 185                    |
| <b>L<sub>1</sub> min</b> | 138-150 *              | 138-174 *              | 138-186 *              | 138-186 *              | 138-186 *              |

\* per il calcolo di L1 vedi tabelle pagina seguente / to determine L1 look at the following page / para el cálculo de L1 ver tablas en la página siguiente / pour le calcul de L1 voir les tableaux de la page suivante / zur Berechnung von L1 siehe Tabellen auf der folgenden Seite

Y ingombro scala a terra (pag. 4)/ floor space used downstairs (pag. 4)/ espacio ocupado por la escalera en el piso inferior (pag. 4)/ encombrement escalier au sol (pag. 4)/ Treppenausmass auf dem Boden (pag. 4)

tutte le dimensioni sono espresse in cm / all dimensions are expressed in cm / todas las dimensiones se expresan en cm / toutes les dimensions sont exprimées en cm / Alle Maße sind in cm angegeben

**CALCOLO L1: valori minimi indicativi / DETERMINATION L1: indicative minimum values / CÁLCULO L1: valores mínimos indicativos / CALCUL L1: valeurs minimales indicatives / BERECHNUNG L1: indikative Mindestwerte**

| HT         | n          |
|------------|------------|
| 220≤HT<225 | 10         |
| S<30       | <b>150</b> |
| S≥30       | <b>162</b> |

| HT         | n          |
|------------|------------|
| 225≤HT<230 | 10         |
| S<35       | <b>150</b> |
| S≥35       | <b>162</b> |

| HT         | n          |
|------------|------------|
| 230≤HT<235 | 10         |
| 20<S<40    | <b>150</b> |
| S≥40       | <b>162</b> |

| HT         | n          |
|------------|------------|
| 235≤HT<240 | 10         |
| S<25       | <b>138</b> |
| 25≤S<45    | <b>150</b> |
| S≥45       | <b>162</b> |

| HT         | n          | n          |
|------------|------------|------------|
| 240≤HT<245 | 10         | 11         |
| S≤30       | <b>138</b> | <b>150</b> |
| 30<S≤50    | <b>150</b> | <b>162</b> |

| HT         | n          | n          |
|------------|------------|------------|
| 245≤HT<250 | 10         | 11         |
| S≤35       | <b>138</b> | <b>150</b> |
| 35<S≤55    | <b>150</b> | <b>162</b> |

| HT         | n          | n          |
|------------|------------|------------|
| 250≤HT<255 | 10         | 11         |
| S≤40       | <b>138</b> | <b>150</b> |
| 40<S≤60    | <b>150</b> | <b>162</b> |

| HT         | n          | n          |
|------------|------------|------------|
| 255≤HT<260 | 10         | 11         |
| S≤45       | <b>138</b> | <b>150</b> |
| 45<S≤65    | <b>150</b> | <b>162</b> |

| HT         | n          | n          |
|------------|------------|------------|
| 260≤HT<265 | 11         | 12         |
| S≤25       | <b>138</b> | <b>150</b> |
| 25<S≤30    | <b>150</b> | <b>150</b> |
| 30<S≤50    | <b>150</b> | <b>162</b> |
| 50<S≤70    | <b>162</b> | <b>174</b> |

| HT         | n          | n          |
|------------|------------|------------|
| 265≤HT<270 | 11         | 12         |
| S≤30       | <b>138</b> | <b>150</b> |
| 30<S<35    | <b>150</b> | <b>150</b> |
| 35≤S≤55    | <b>150</b> | <b>162</b> |
| 55<S≤75    | <b>162</b> | <b>174</b> |

| HT         | n          | n          |
|------------|------------|------------|
| 270≤HT<275 | 11         | 12         |
|            | <b>138</b> | <b>150</b> |
| 35<S<40    | <b>150</b> | <b>150</b> |
| 40≤S≤60    | <b>150</b> | <b>162</b> |
| 60<S≤80    | <b>162</b> | <b>174</b> |

| HT         | n          | n          |
|------------|------------|------------|
| 275≤HT<280 | 11         | 12         |
| S≤40       | <b>138</b> | <b>150</b> |
| 40<S<45    | <b>150</b> | <b>150</b> |
| 45≤S≤65    | <b>150</b> | <b>162</b> |
| 65<S≤85    | <b>162</b> | <b>174</b> |

| HT         | n          | n          | n          |
|------------|------------|------------|------------|
| 280≤HT<285 | 11         | 12         | 13         |
| S≤45       | <b>138</b> | <b>150</b> | <b>162</b> |
| 45<S≤50    | <b>150</b> | <b>162</b> | <b>162</b> |
| 50<S≤70    | <b>150</b> | <b>162</b> | <b>174</b> |
| 70<S≤90    | <b>162</b> | <b>174</b> | <b>174</b> |

| HT         | n          | n          |
|------------|------------|------------|
| 285≤HT<290 | 12         | 13         |
| S≤30       | <b>138</b> | <b>150</b> |
| 30<S<55    | <b>150</b> | <b>162</b> |
| 55≤S<80    | <b>162</b> | <b>174</b> |
| 80≤S≤95    | <b>174</b> | <b>186</b> |

| HT         | n          | n          |
|------------|------------|------------|
| 290≤HT<295 | 12         | 13         |
| S≤35       | <b>138</b> | <b>150</b> |
| 35<S≤55    | <b>150</b> | <b>162</b> |
| 55<S≤80    | <b>162</b> | <b>174</b> |
| 80<S≤100   | <b>174</b> | <b>186</b> |

| HT         | n          | n          |
|------------|------------|------------|
| 295≤HT<300 | 12         | 13         |
| S≤35       | <b>138</b> | <b>150</b> |
| 35<S≤55    | <b>150</b> | <b>162</b> |
| 55<S≤80    | <b>162</b> | <b>174</b> |
| 80<S≤105   | <b>174</b> | <b>186</b> |

| HT         | n          | n          | n          |
|------------|------------|------------|------------|
| 300≤HT<305 | 12         | 13         | 14         |
| S≤30       | <b>138</b> | <b>150</b> | <b>150</b> |
| 30<S≤40    | <b>138</b> | <b>150</b> | <b>162</b> |
| 40<S<55    | <b>150</b> | <b>162</b> | <b>162</b> |
| 55≤S≤65    | <b>150</b> | <b>162</b> | <b>174</b> |
| 65<S≤90    | <b>162</b> | <b>174</b> | <b>186</b> |

| HT         | n          | n          | n          |
|------------|------------|------------|------------|
| 305≤HT<310 | 12         | 13         | 14         |
| S<35       | <b>138</b> | <b>150</b> | <b>150</b> |
| 35≤S≤35    | <b>138</b> | <b>150</b> | <b>162</b> |
| 45<S<55    | <b>150</b> | <b>162</b> | <b>162</b> |
| 55≤S≤70    | <b>150</b> | <b>162</b> | <b>174</b> |
| 70<S≤95    | <b>162</b> | <b>174</b> | <b>186</b> |

| HT         | n          | n          |
|------------|------------|------------|
| 310≤HT<315 | 13         | 14         |
| S≤30       | <b>138</b> | <b>150</b> |
| 30<S≤55    | <b>150</b> | <b>162</b> |
| 55<S≤75    | <b>162</b> | <b>174</b> |
| 75<S≤100   | <b>174</b> | <b>186</b> |

| HT         | n          | n          |
|------------|------------|------------|
| 315≤HT<320 | 13         | 14         |
| S≤35       | <b>138</b> | <b>150</b> |
| 35<S≤55    | <b>150</b> | <b>162</b> |
| 55<S≤80    | <b>162</b> | <b>174</b> |
| 80<S≤105   | <b>174</b> | <b>186</b> |

| HT         | n          | n          |
|------------|------------|------------|
| 320≤HT<325 | 13         | 14         |
| S≤40       | <b>138</b> | <b>150</b> |
| 40<S≤65    | <b>150</b> | <b>162</b> |
| 65≤S≤85    | <b>162</b> | <b>174</b> |
| 85<S≤110   | <b>174</b> | <b>186</b> |

| HT         | n          | n          |
|------------|------------|------------|
| 325≤HT<330 | 13         | 14         |
| S<45       | <b>138</b> | <b>150</b> |
| 45≤S<70    | <b>150</b> | <b>162</b> |
| 70≤S≤90    | <b>162</b> | <b>174</b> |
| 90<S≤115   | <b>174</b> | <b>186</b> |

| HT         | n          | n          |
|------------|------------|------------|
| 330≤HT<335 | 13         | 14         |
| S≤30       | <b>138</b> | <b>138</b> |
| 30<S<50    | <b>138</b> | <b>150</b> |
| 50≤S≤70    | <b>150</b> | <b>162</b> |
| 70<S≤95    | <b>162</b> | <b>174</b> |
| 95<S≤120   | <b>174</b> | <b>186</b> |

| HT         | n          |
|------------|------------|
| 335≤HT<340 | 14         |
| S≤35       | <b>138</b> |
| 35<S<60    | <b>150</b> |
| 60≤S≤80    | <b>162</b> |
| 80<S≤100   | <b>174</b> |
| 100<S≤125  | <b>186</b> |

| HT         | n          |
|------------|------------|
| 340≤HT<345 | 14         |
| S≤35       | <b>138</b> |
| 35<S<65    | <b>150</b> |
| 65≤S≤80    | <b>162</b> |
| 80<S≤100   | <b>174</b> |
| 100<S≤125  | <b>186</b> |

| HT         | n          |
|------------|------------|
| 345≤HT<350 | 14         |
| S≤40       | <b>138</b> |
| 40<S≤65    | <b>150</b> |
| 65<S<90    | <b>162</b> |
| 90≤S≤110   | <b>174</b> |
| 110<S≤135  | <b>186</b> |

| HT         | n          |
|------------|------------|
| 350≤HT<356 | 14         |
| S≤45       | <b>138</b> |
| 45<S<70    | <b>150</b> |
| 70≤S≤90    | <b>162</b> |
| 90<S≤115   | <b>174</b> |
| 110<S≤140  | <b>186</b> |

INGOMBRO SCALA A TERRA (Y) / FLOOR SPACE USED DOWNSTAIRS (Y) / ESPACIO OCUPADO POR LA ESCALERA EN EL PISO INFERIOR (Y) / ENCOMBREMENT ESCALIER AU SOL (Y) / TREPPENAUSMASS AUF DEM BODEN (Y)

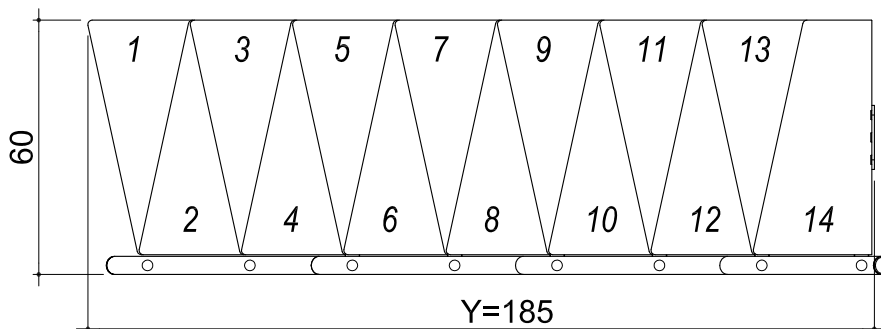
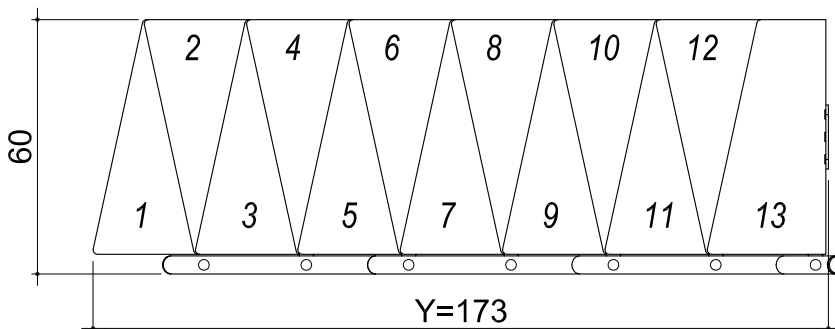
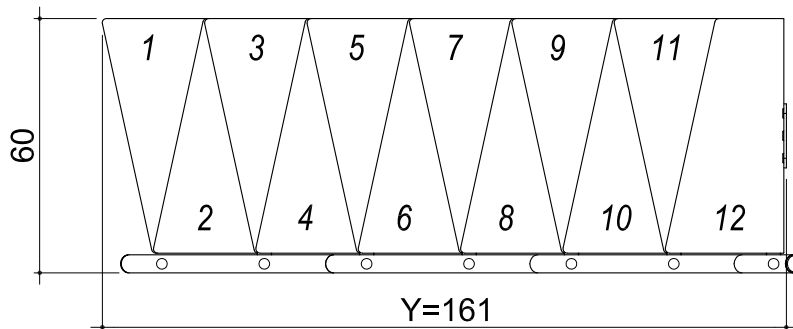
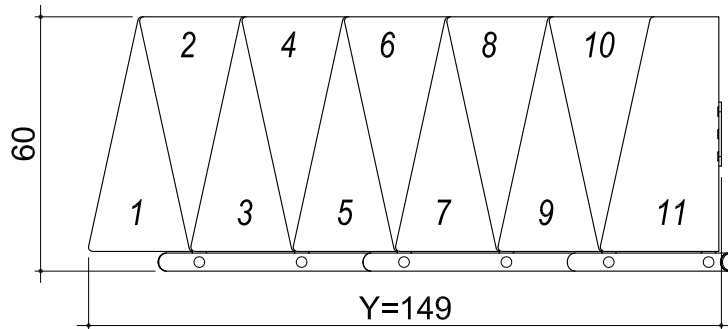
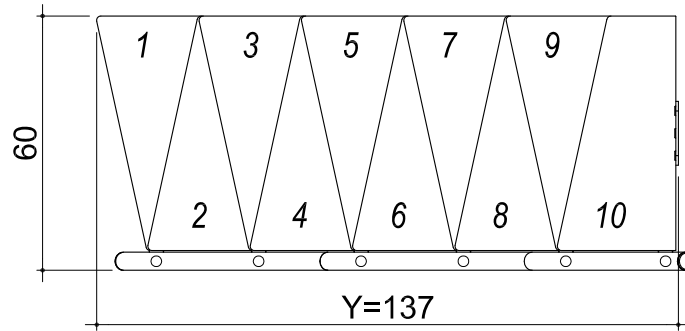

UTENSILI NECESSARI / NECESSARY TOOLS / HERRAMIENTAS NECESARIAS / OUTILS NÉCESSAIRES / NOTWENDIGE WERKZEUGE



**COMPONENTI DELLA SCALA / COMPONENTS OF THE STAIR / COMPONENTES DE LA ESCALA / COMPOSANTS DE L'ESCALIER / TREPPEN-KOMPONENTEN**

**SCALA 11 GRADINI / STAIR 11 STEPS / ESCALERA 11 PELDAÑOS / ESCALIER 11 MARCHES / TREPPE 11 STUFEN**

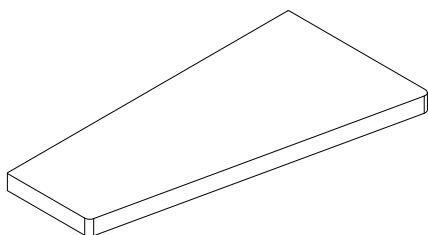

110000812  
x 11

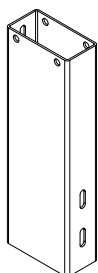

600651001/22  
x 10

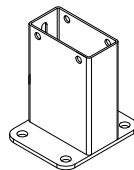

600650001/22  
x 1

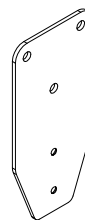

600653001/22  
x 1

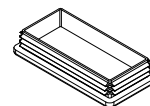

640074401/22  
x 10

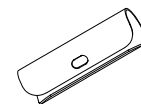

600409314  
x 2

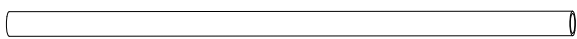

996400101/22  
x 3

Ø 4,2 L=100



600271501/22  
x 1

Ø 2,5 L=140



600269001/22  
x 5

Ø 2,5 L=116

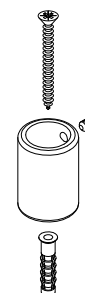

703230101/22  
x 1



640095014  
x 2



640650501/22  
x 2



640069501/22  
x 1

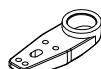

640070101/22  
x 16



640079101/22  
x 5



640068101/22  
x 44

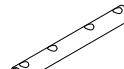

600410010  
x 22



640064601/22  
x 6



640064701/22  
x 6

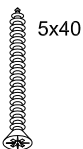

630142509  
x 44

5x40



630142009  
x 12

5x20

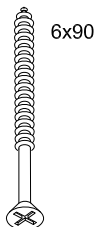

630145510  
x 1

6x90



640081014  
x 1



630201009  
x 17

4x20

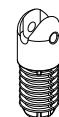

640064501/22  
x 6



640064801/22  
x 6

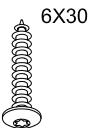

630113910  
x 16

6X30

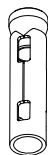

630333010  
x 7



630180010  
x 7

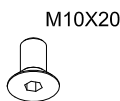

630135110  
x 2

M10X20



630111910  
x 20

M10X20



630102710  
x 22

M10

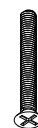

630144810  
x 6

M6X50

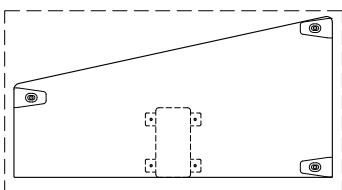

650536500  
x 1

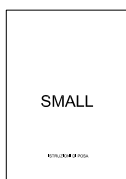

650535100  
x 1

SMALL

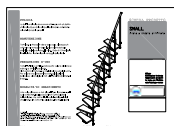

650536100  
x 1

M10X18



630102909  
x 7



630330210  
x 42



M6

630102010  
x 6



**COMPONENTI DELLA SCALA / COMPONENTS OF THE STAIR / COMPONENTES DE LA ESCALA / COMPOSANTS DE L'ESCALIER / TREPPEN-KOMPONENTEN**

**SCALA 10 GRADINI / STAIR 10 STEPS / ESCALERA 10 PELDAÑOS / ESCALIER 10 MARCHES / TREPPE 10 STUFEN**

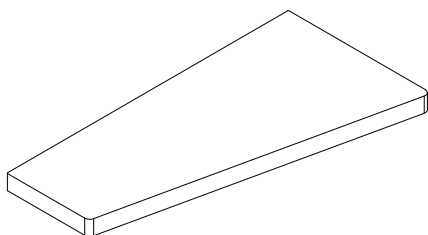

110000812  
x 10

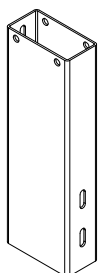

600651001/22  
x 9

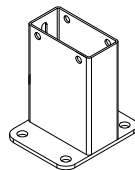

600650001/22  
x 1

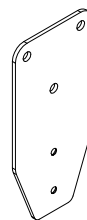

600653001/22  
x 1

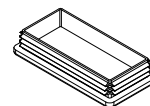

640074401/22  
x 9

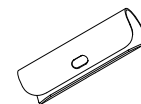

600409314  
x 2



996400101/22  
x 3

Ø 4,2 L=100



600271501/22  
x 1

Ø 2,5 L=140



600269001/22  
x 4

Ø 2,5 L=116

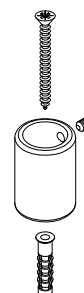

703230101/22  
x 1



640095014  
x 2



640650501/22  
x 2



640069501/22  
x 1

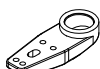

640070101/22  
x 15



640079101/22  
x 4



640068101/22  
x 40

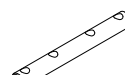

600410010  
x 20



640064601/22  
x 5



640064701/22  
x 5

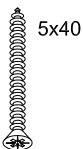

630142509  
x 40

5x40



630142009  
x 10

5x20

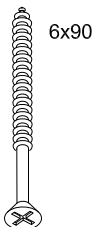

630145510  
x 1

6x90



640081014  
x 1



630201009  
x 16

4x20



640064501/22  
x 5



640064801/22  
x 5

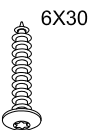

630113910  
x 15

6X30

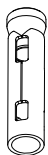

630333010  
x 7



630180010  
x 7

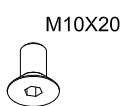

630135110  
x 2

M10X20



630111910  
x 18

M10X20



630102710  
x 20

M10

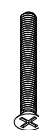

630144810  
x 5

M6X50

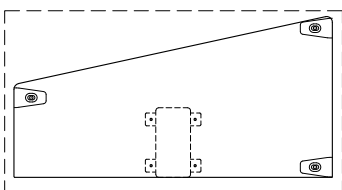

650536500  
x 1

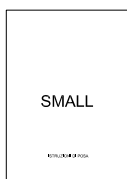

650535100  
x 1

SMALL

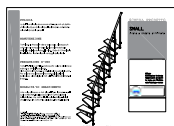

650536100  
x 1

M10X18



630102909  
x 7



630330210  
x 38



630102010  
x 5

M6

**COMPONENTI DELLA SCALA / COMPONENTS OF THE STAIR / COMPONENTES DE LA ESCALA / COMPOSANTS DE L'ESCALIER / TREPPEN-KOMPONENTEN**

**GRADINO SUPPLEMENTARE / ADDITIONAL STEP / PELDAÑO ADICIONAL / MARCHE SUPPLÉMENTAIRE / ZUSÄTZLICHER STUFEN**

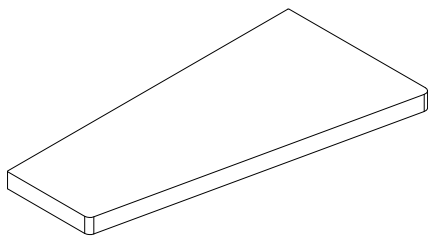

110000812  
x 1

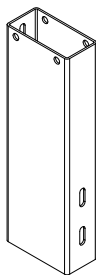

600651001/22  
x 1

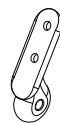

640064601/22  
x 1

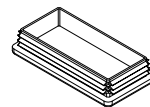

640074401/22  
x 1



640064701/22  
x 1

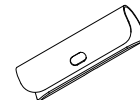

600409314  
x 1

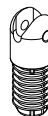

640064501/22  
x 1



640095014  
x 1

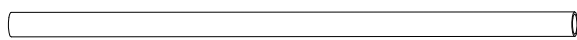

996400101/22  
x 1  
Ø 4,2 L=100



640064801/22  
x 1

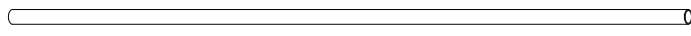

600269001/22  
x 1  
Ø 2,5 L=116



640070101/22  
x 2



640079101/22  
x 1



640068101/22  
x 4

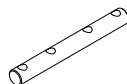

600410010  
x 2



630142509  
x 4  
5x40



630330210  
x 4



630142009  
x 2  
5x20



630144810  
x 1  
M6X50



630201009  
x 2  
4x20

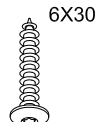

630113910  
x 2  
6X30

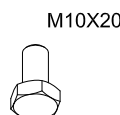

630111910  
x 2  
M10X20



630102710  
x 2  
M10



630102010  
x 1  
M6

**FISSAGGIO SCALA AL SOLAIO / HOW TO FIX THE STAIR TO THE SLAB / FIJACIÓN DE LA ESCALERA AL FORJADO / FIXATION DE L'ESCALIER À LA DALLE / TREPPENBEFESTIGUNG AAN DER ZIMMERDECKE**

**1**

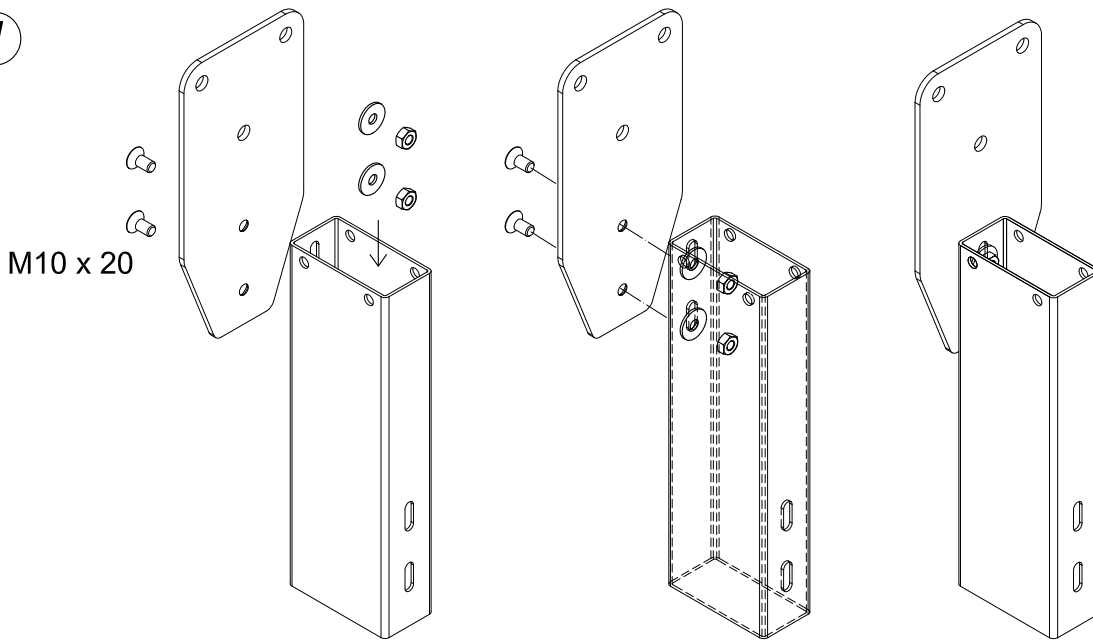

**2**

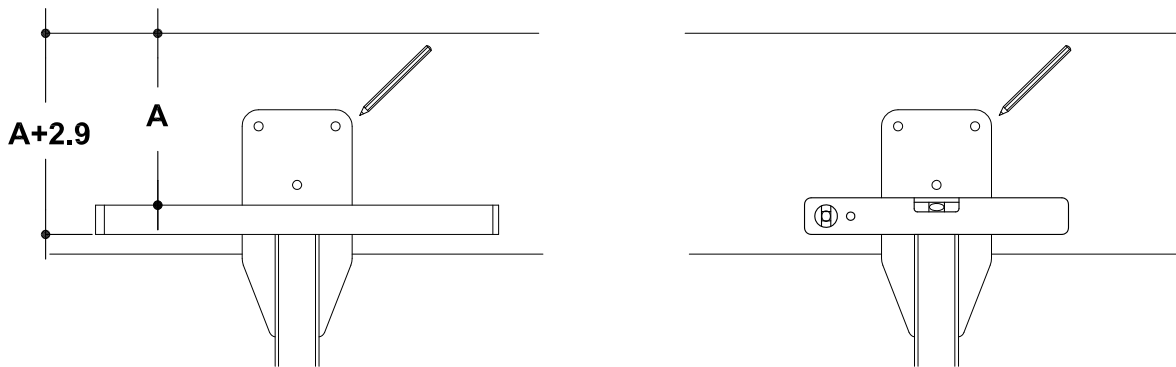

**3**

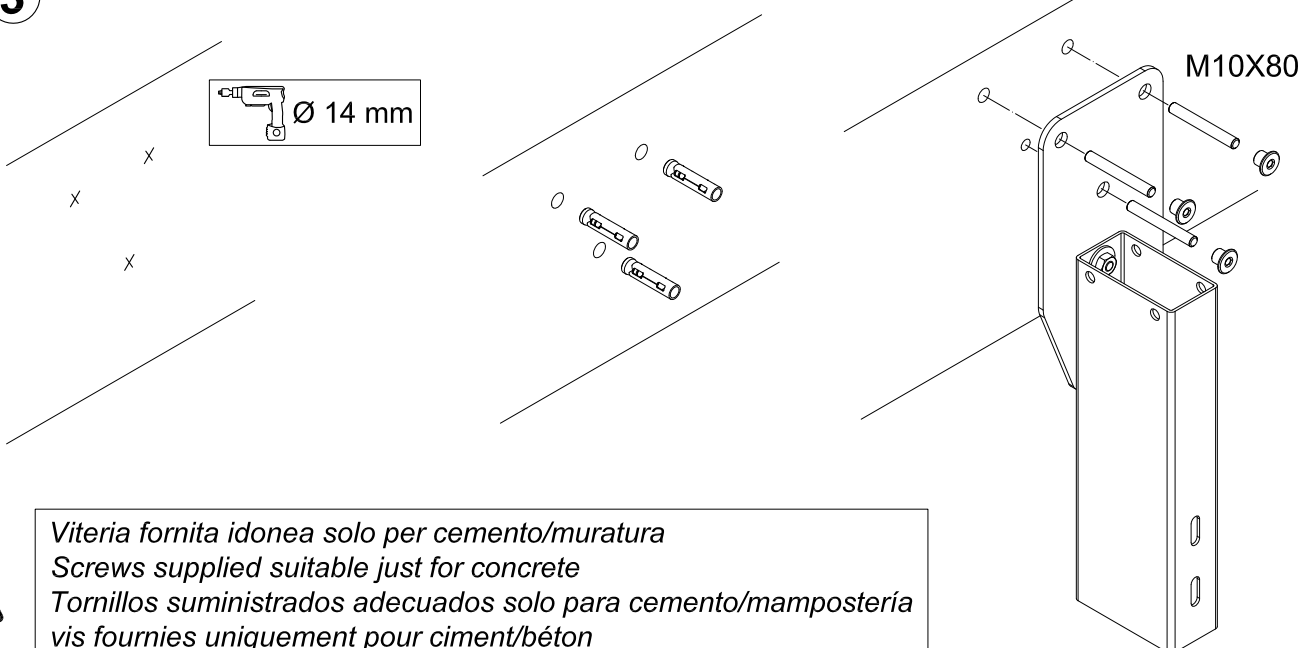

*Viteria fornita idonea solo per cemento/muratura  
Screws supplied suitable just for concrete  
Tornillos suministrados adecuados solo para cemento/mampostería  
vis fournies uniquement pour ciment/béton  
Gelieferte Schrauben nur für Beton/Mauerwerk geeignet*

ASSEMBLAGGIO STRUTTURE / STRUCTURE ASSEMBLY / MONTAJE DE LAS ESTRUCTURAS / ASSEMBLAGE DE STRUCTURES / STRUKTUREN-MONTAGE

4

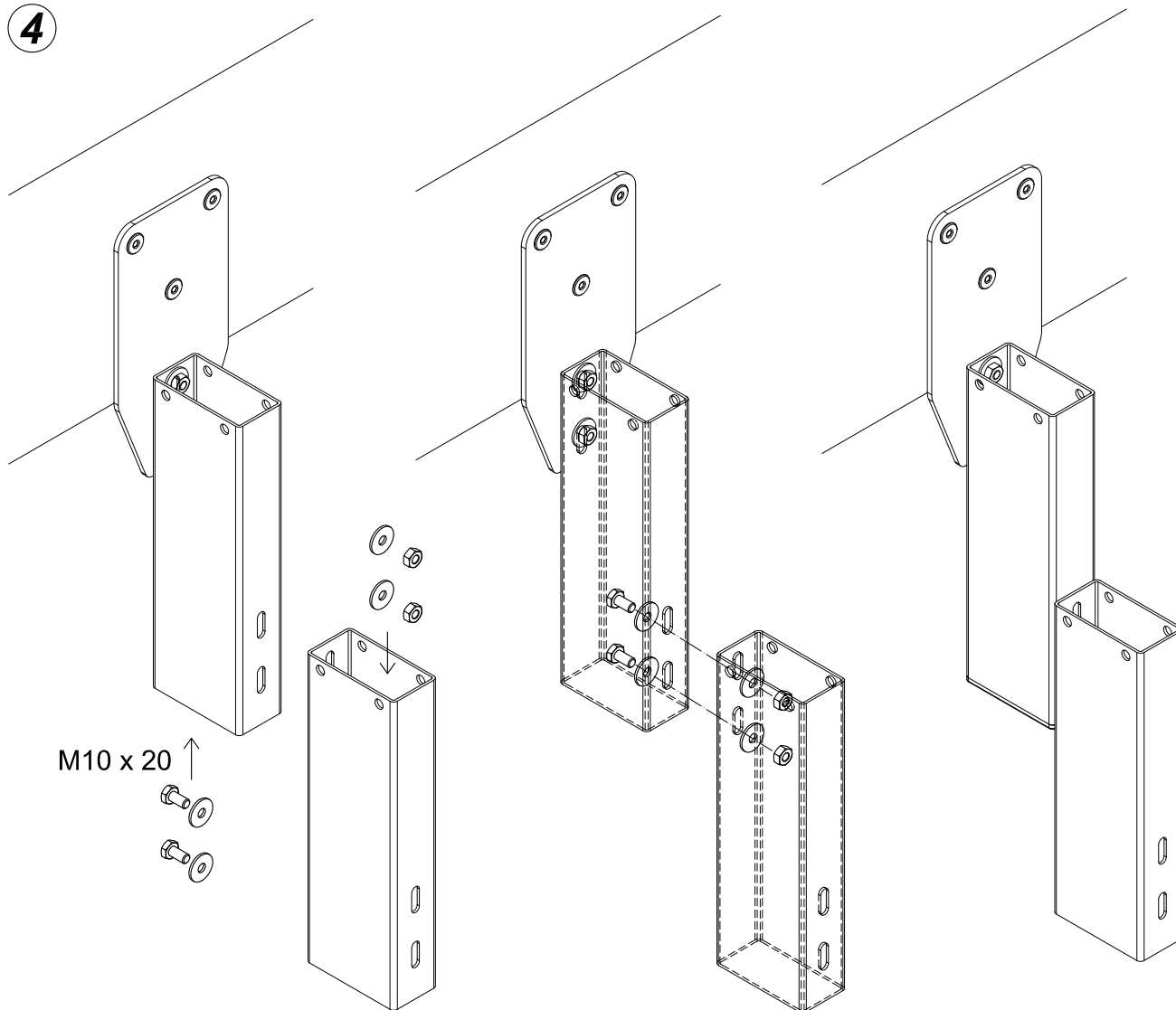

M10 x 20 ↑  
↑  
↑

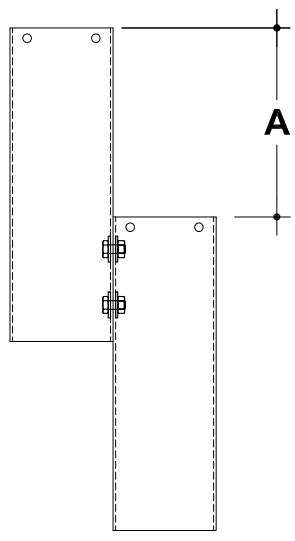

5

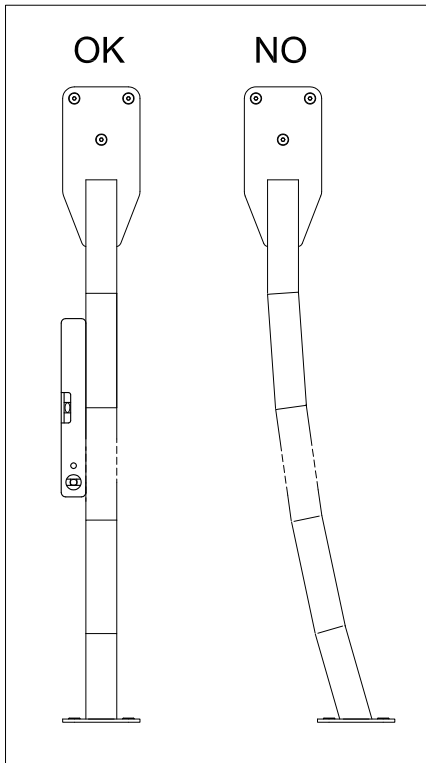
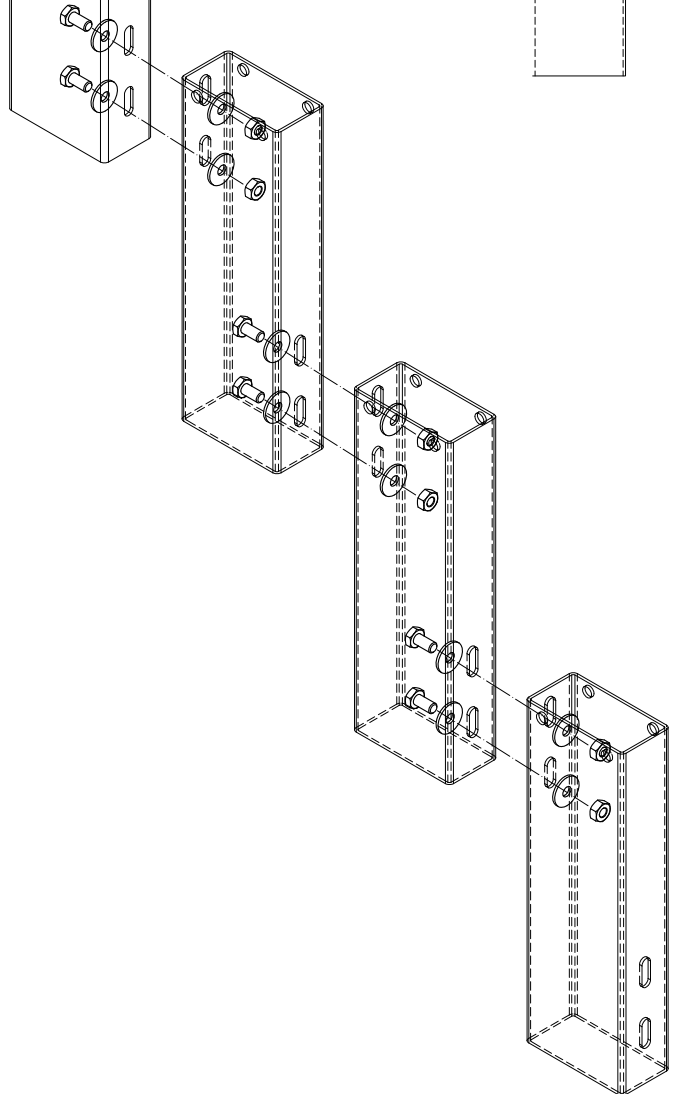
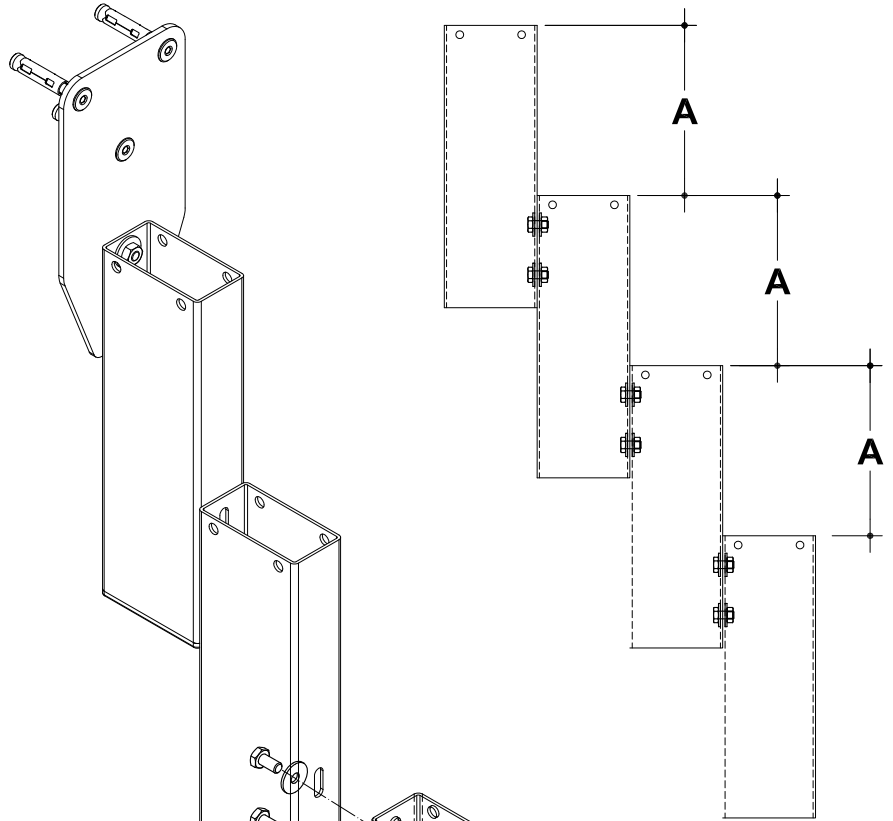

6

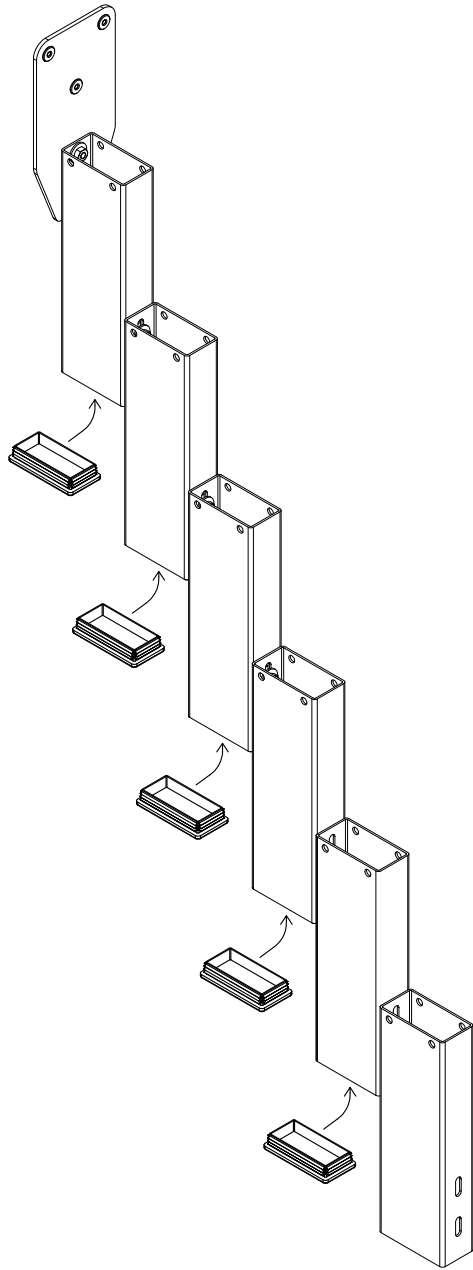

7

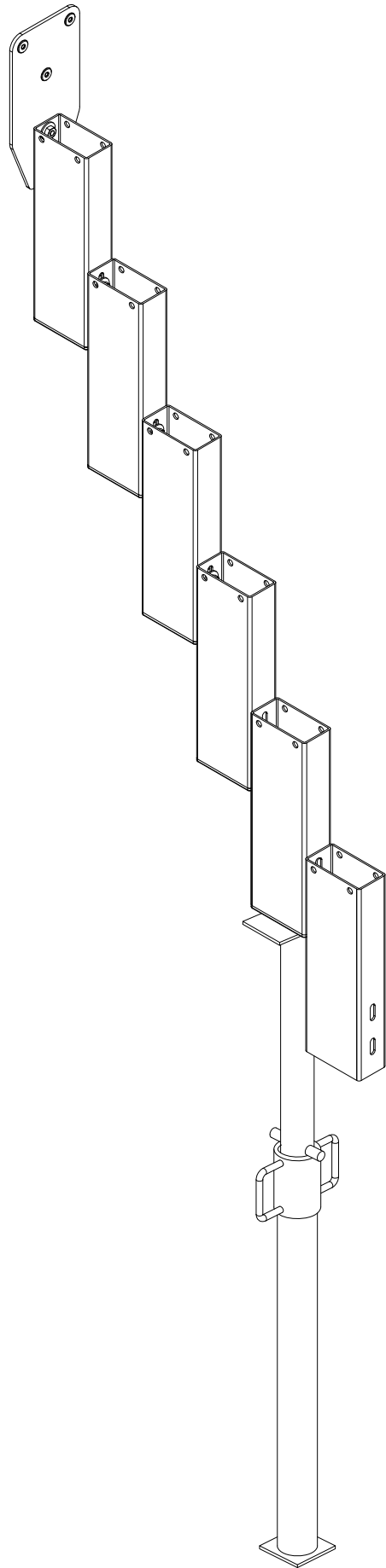

8

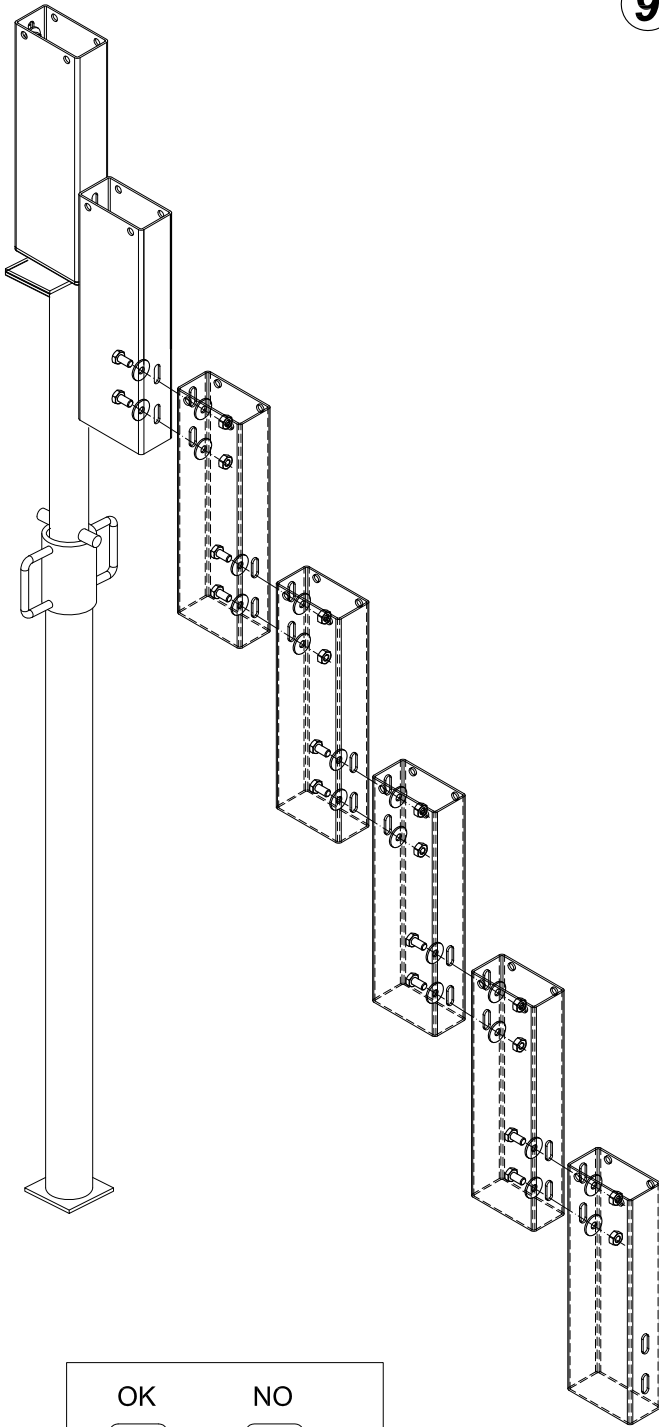

9

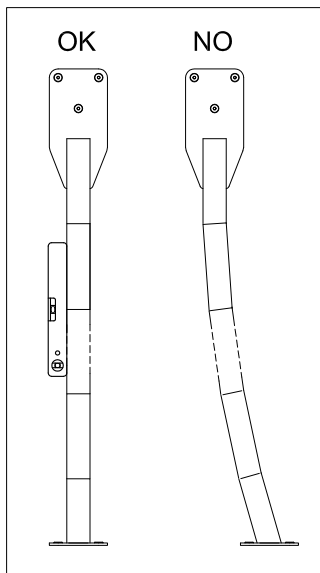
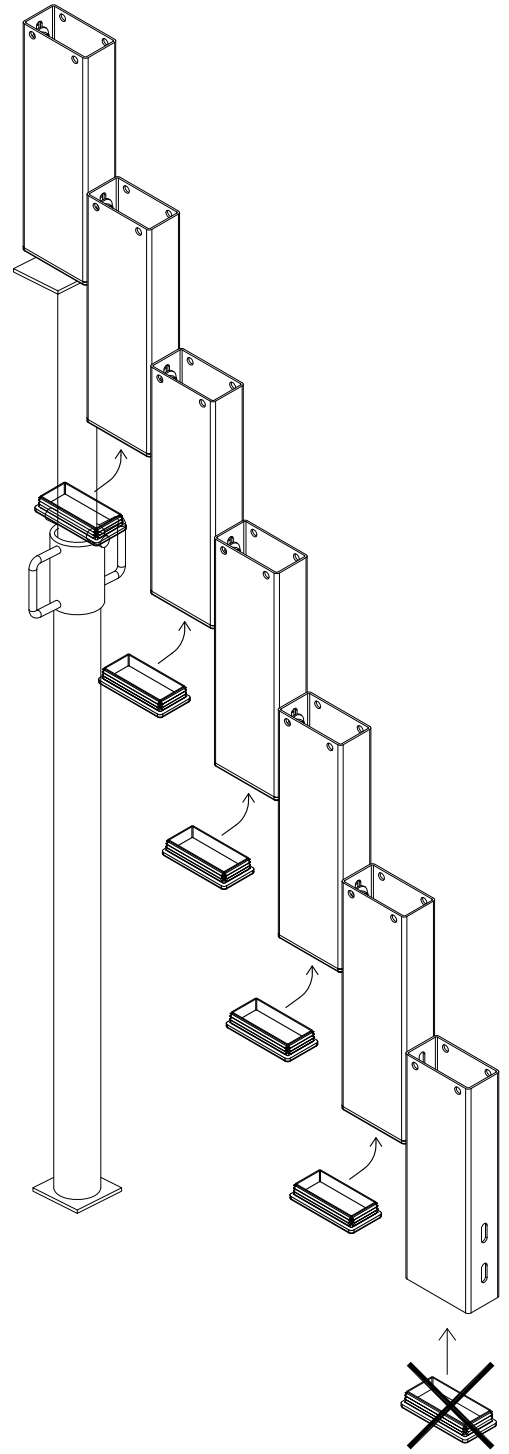

10

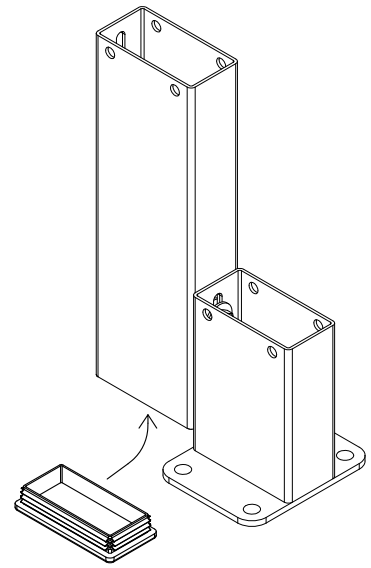
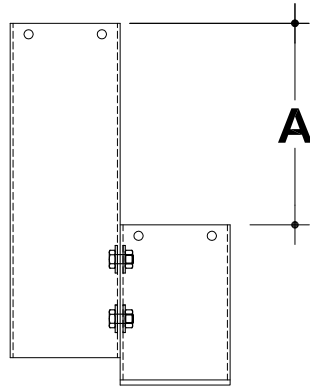
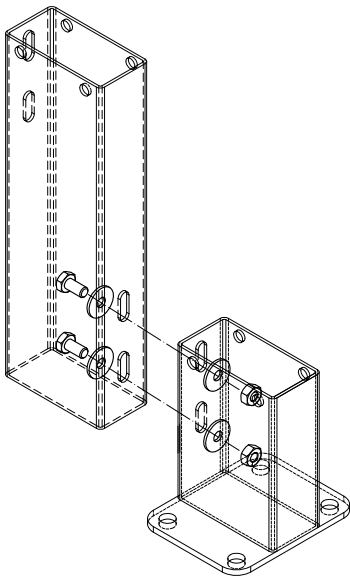

11

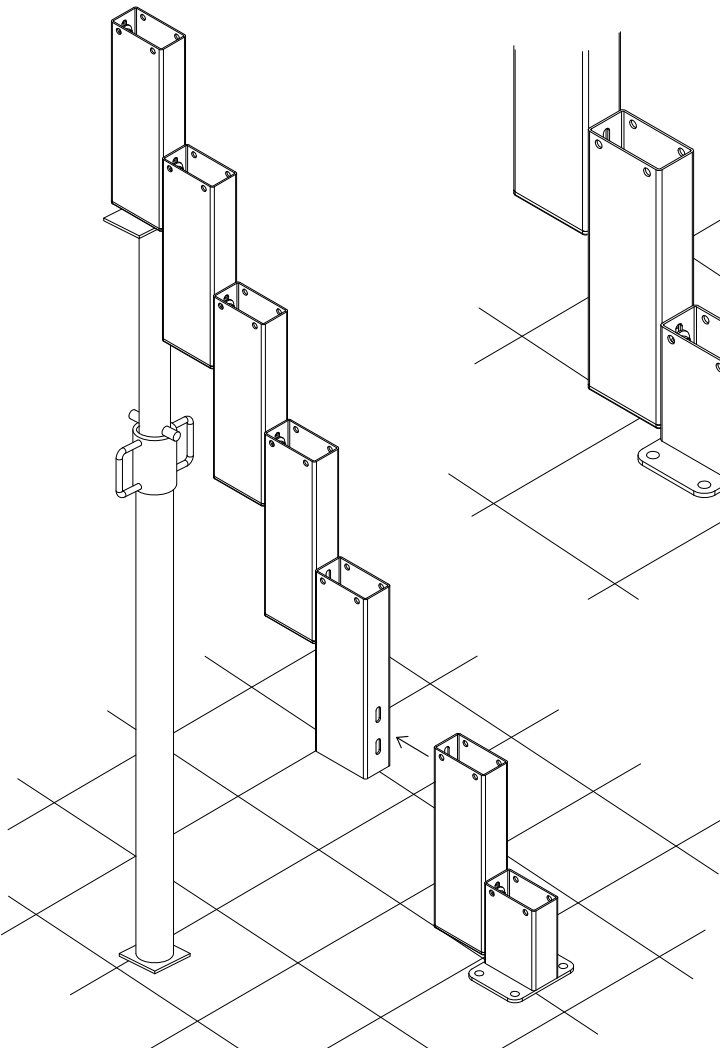

12

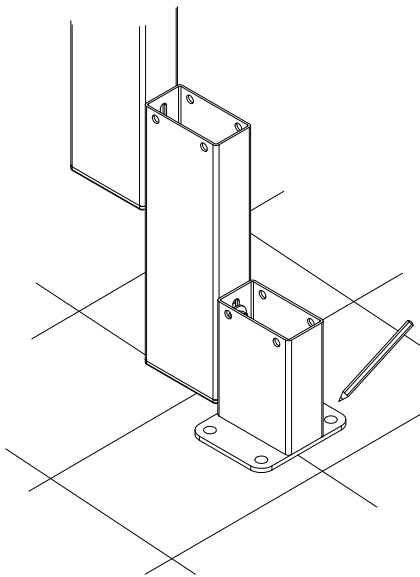

13

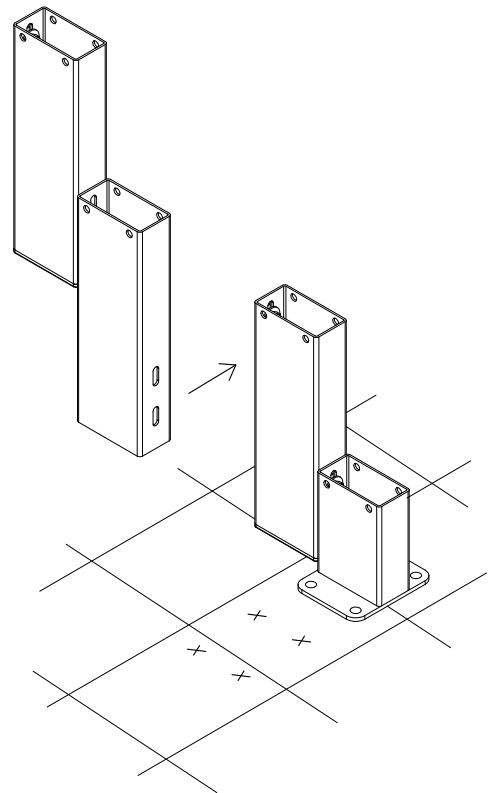



## 1/4 Tournant



# 1/4 Tournant

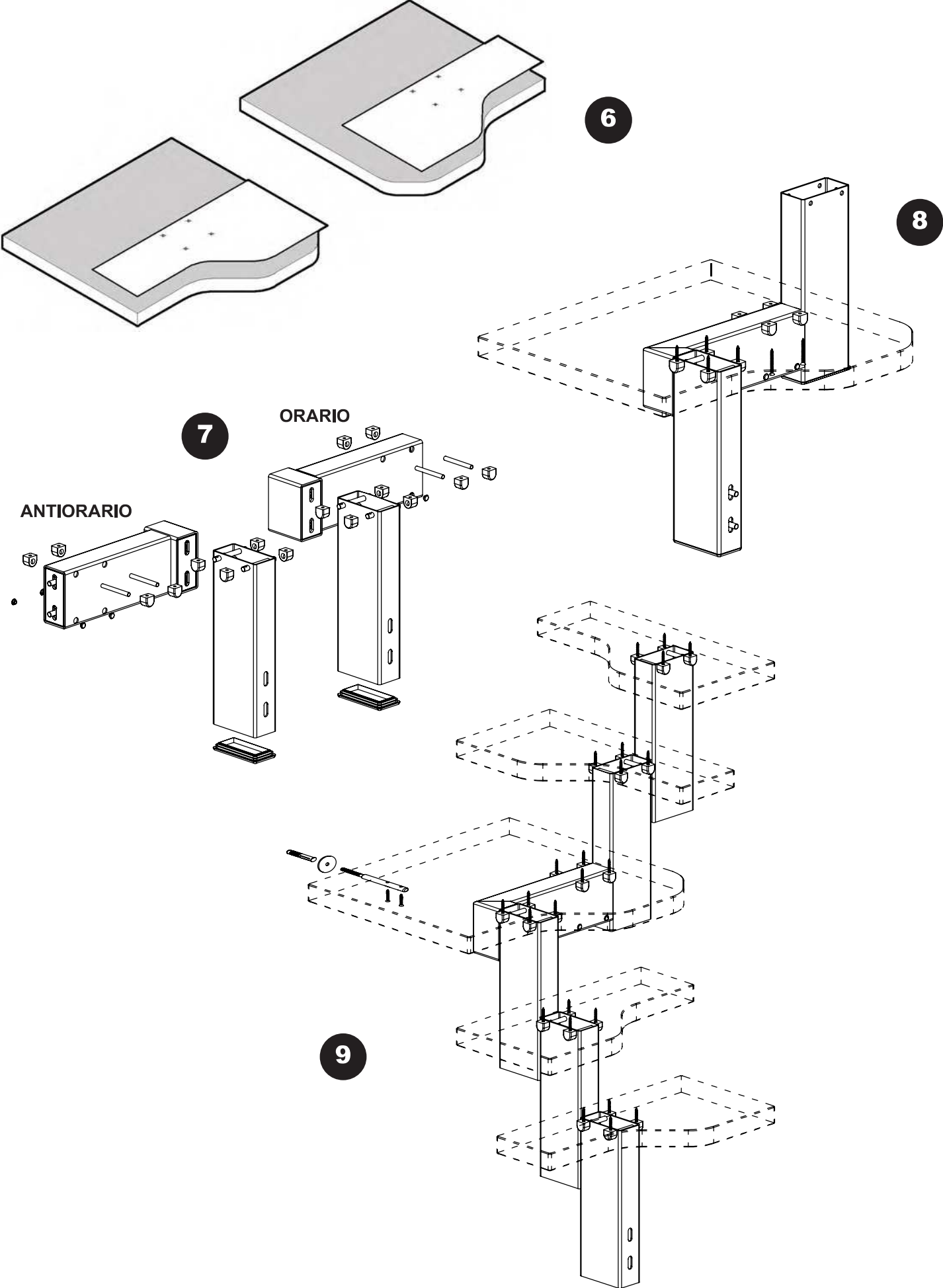

# 1/4 Tournant

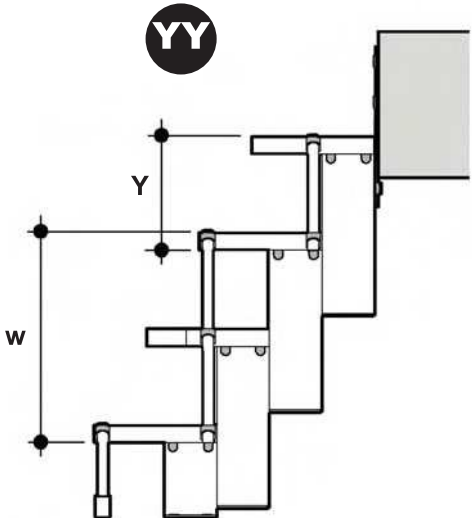
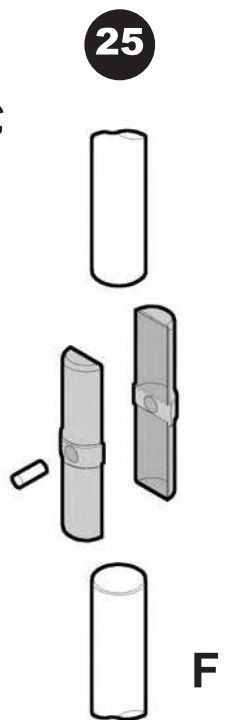
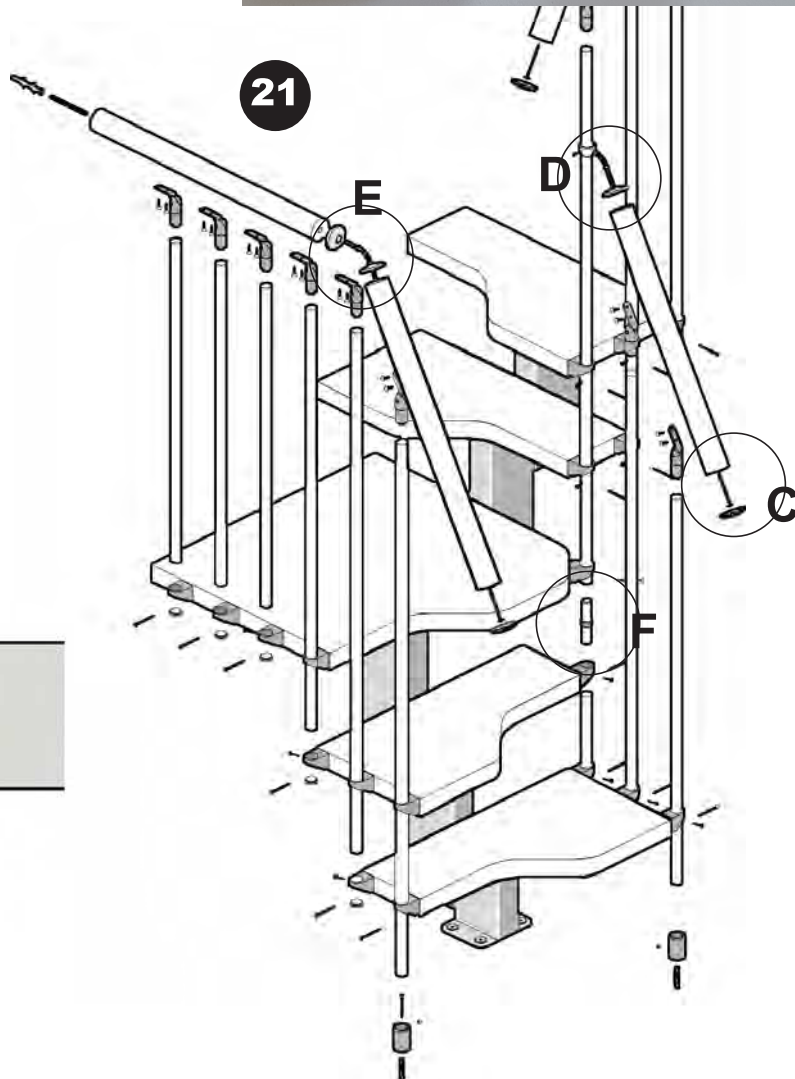
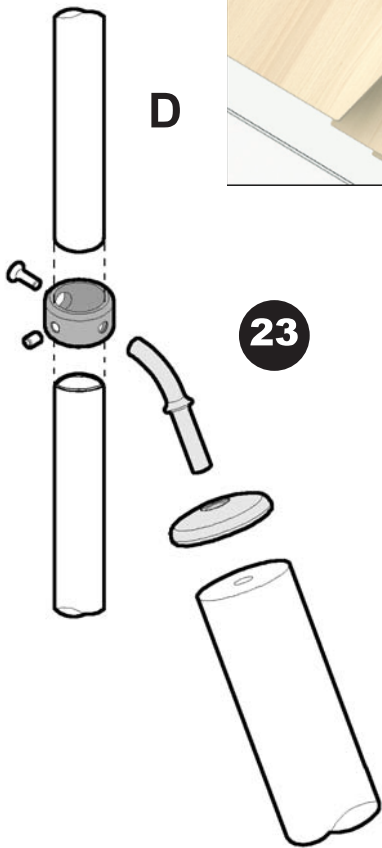

14

Ø 14 mm

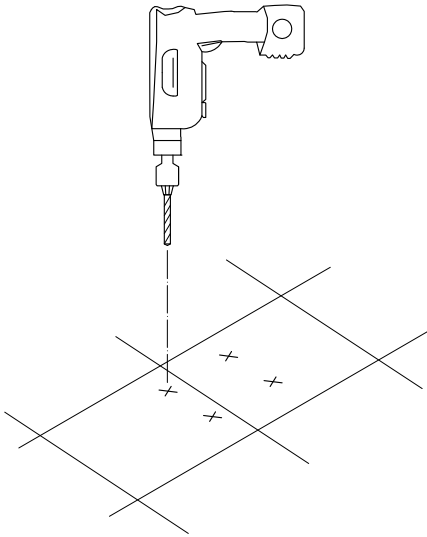

15

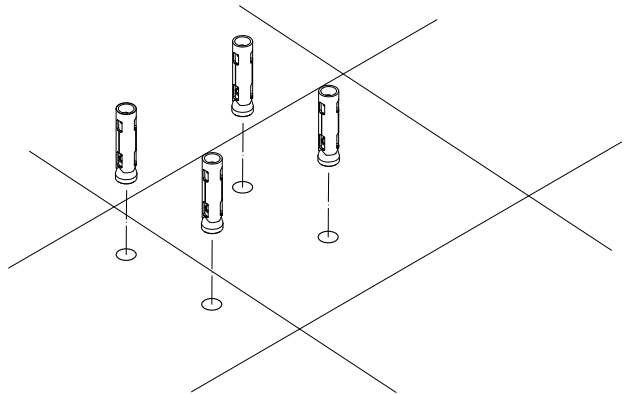

16

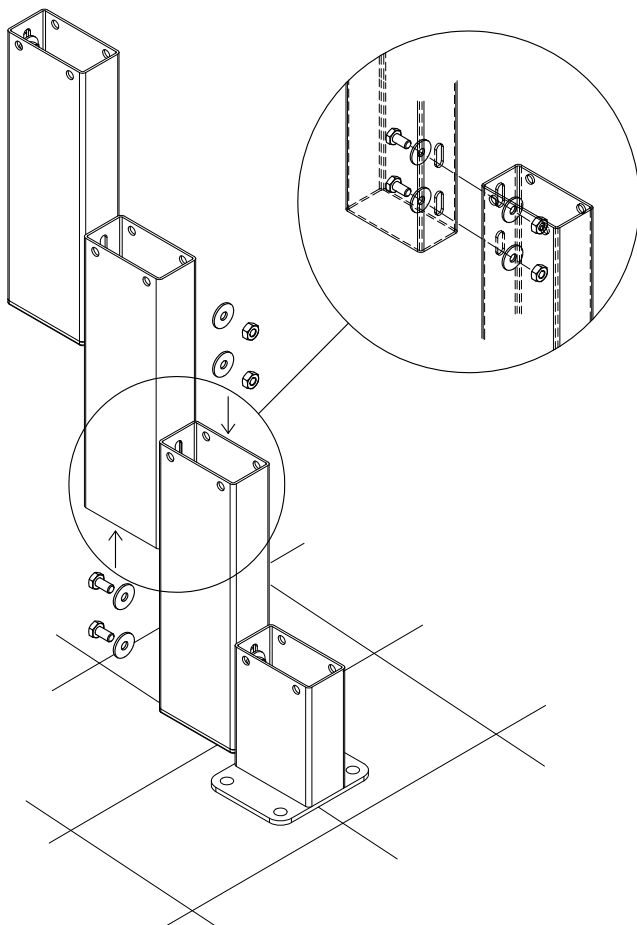

17

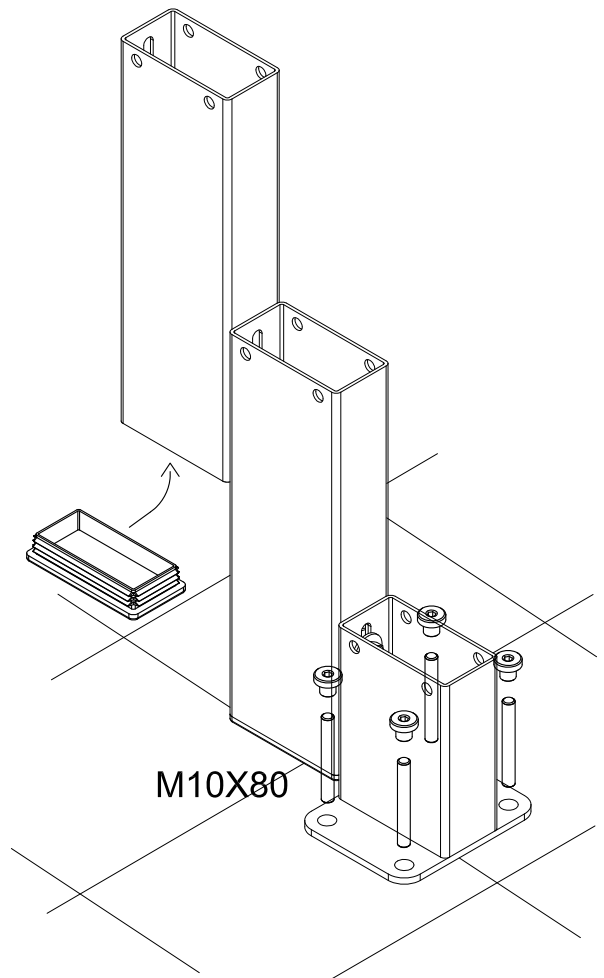

PUNZONATURA GRADINO DI SBARCO / PUNCHING OF THE LANDING / TROQUELADURA DEL DESEMBARCO / POINÇONNAGE PALIER D'ARRIVÉE / BOHRUNGEN AM TREPPENAUSTRITT

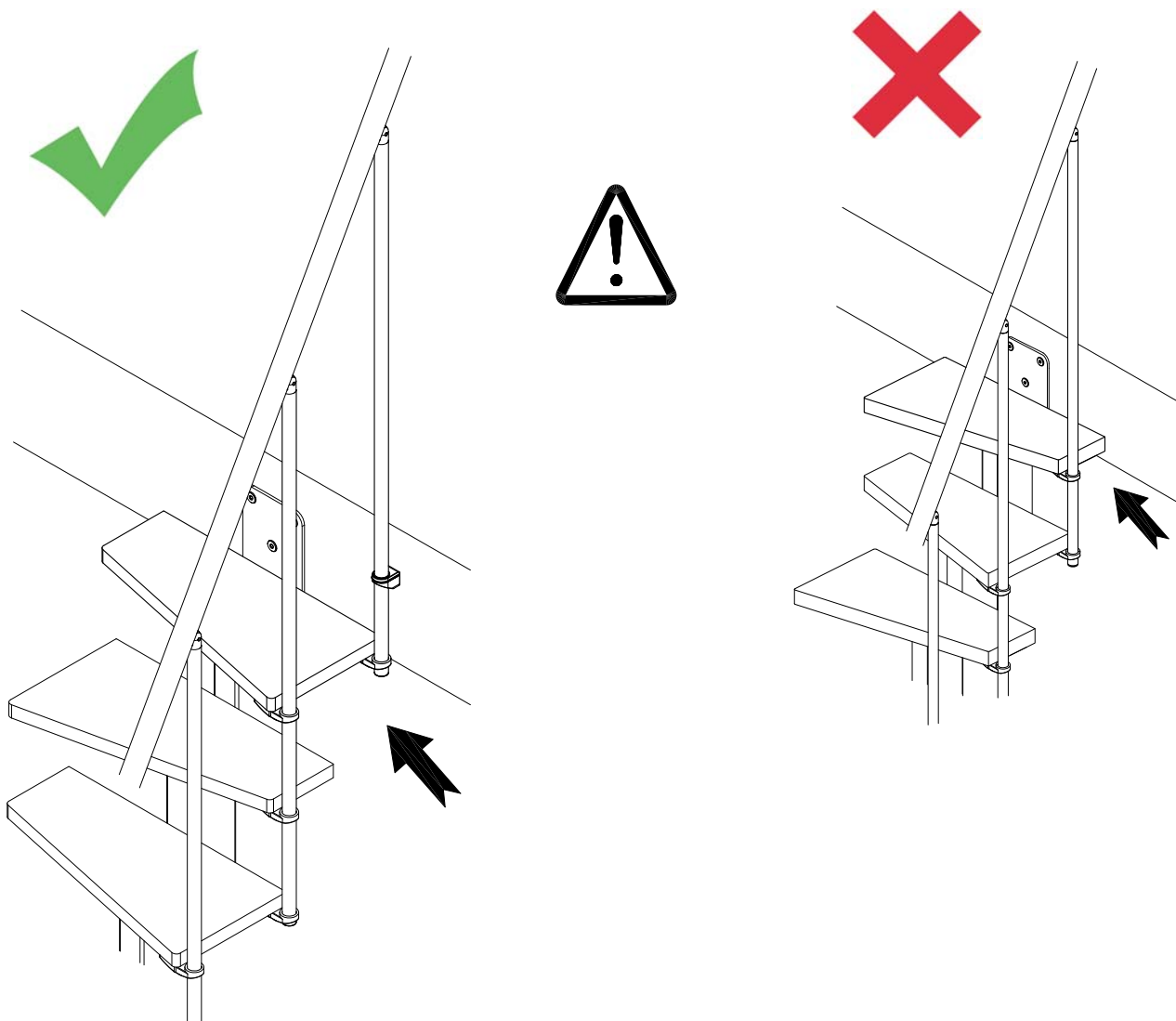

18

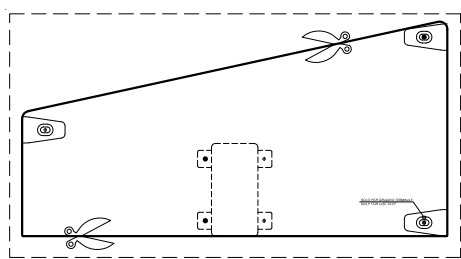

19

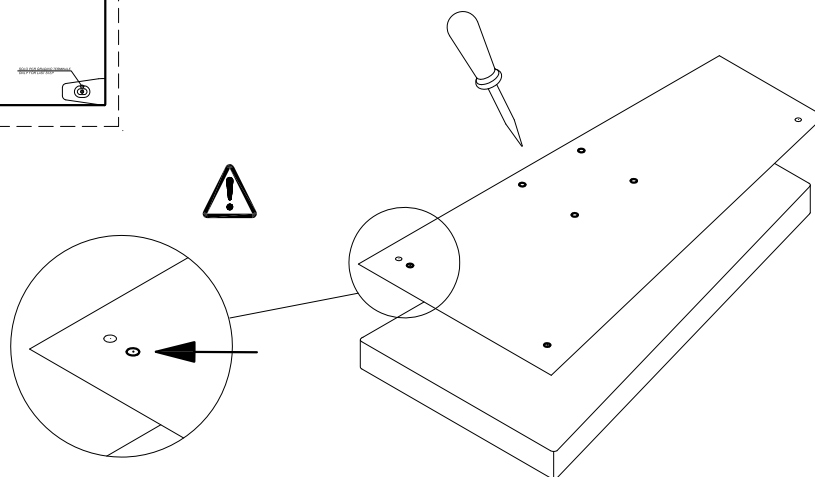

PUNZONATURA ALTRI GRADINI: ringhiera lato destro / PUNCHING OF OTHER STEPS: railing on the right side /  
TROQUELADURA OTROS PELDAÑOS: barandilla lateral derecha / POINÇONNAGE D'AUTRES MARCHES: rampe  
droite / BOHRUNGEN AN ANDERN STUFEN: Geländer auf der rechten Seite

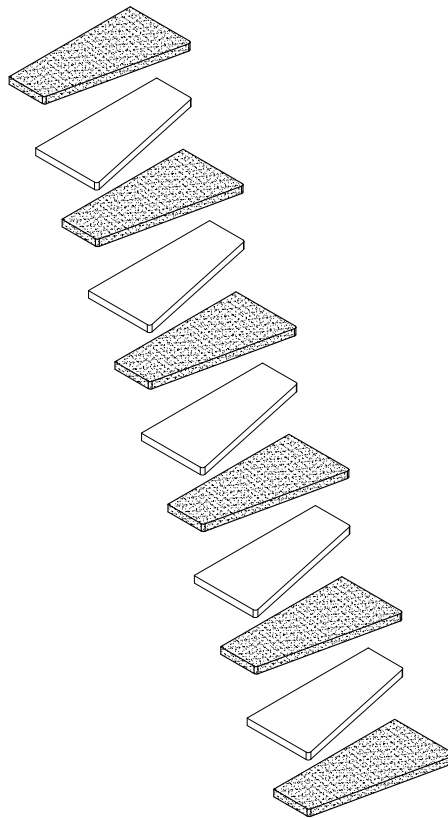
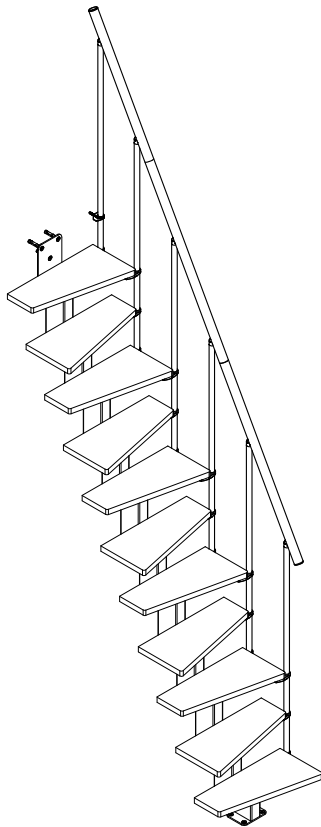

20

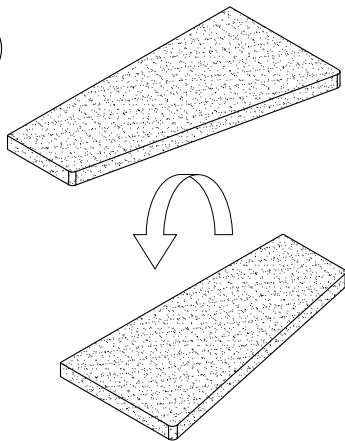

22

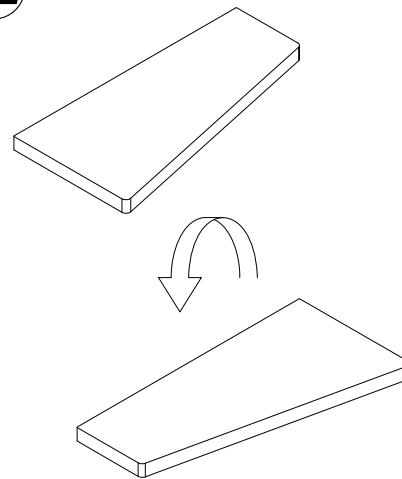

21

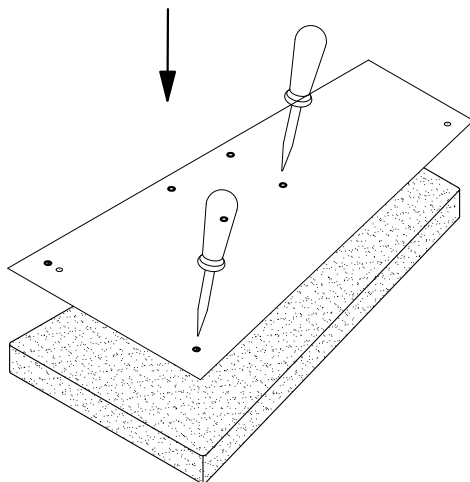

23

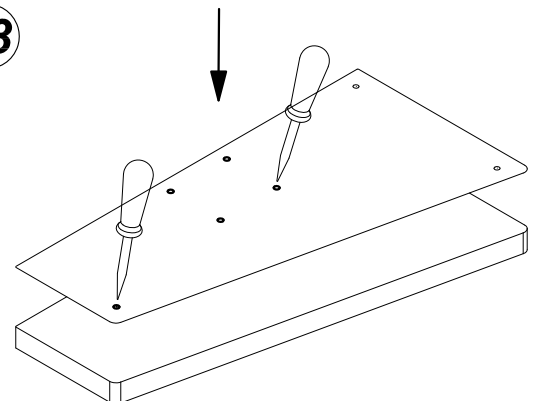

**PUNZONATURA ALTRI GRADINI: ringhiera lato sinistro / PUNCHING OF OTHER STEPS: railing on the left side /**  
**TROQUELADURA OTROS PELDAÑOS: barandilla lateral izquierda / POINÇONNAGE D'AUTRES MARCHES: rampe**  
**gauche / BOHRUNGEN AN ANDERN STUFEN: Geländer auf der linken Seite**

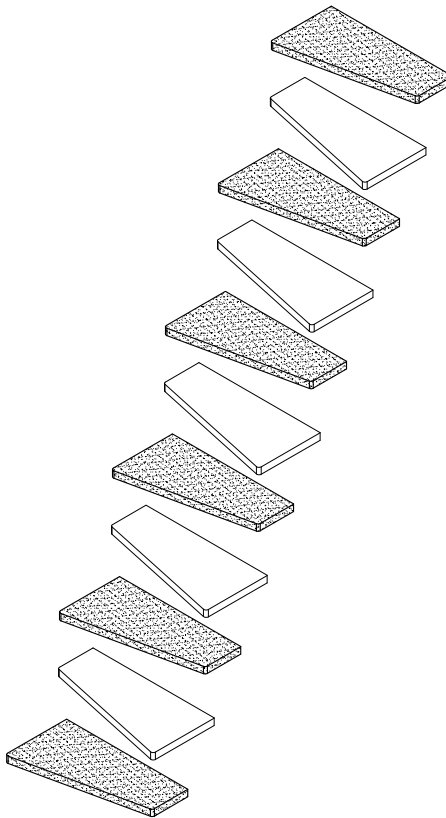
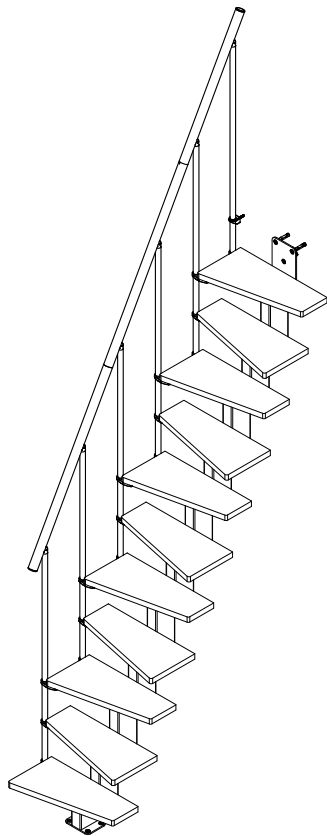

**20**

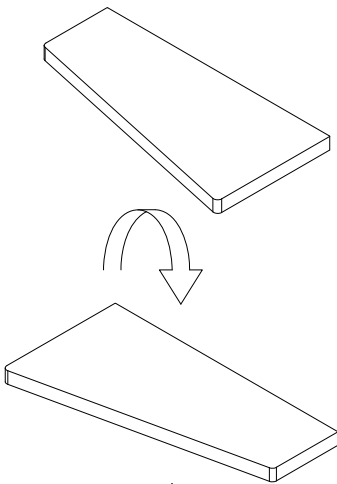

**21**

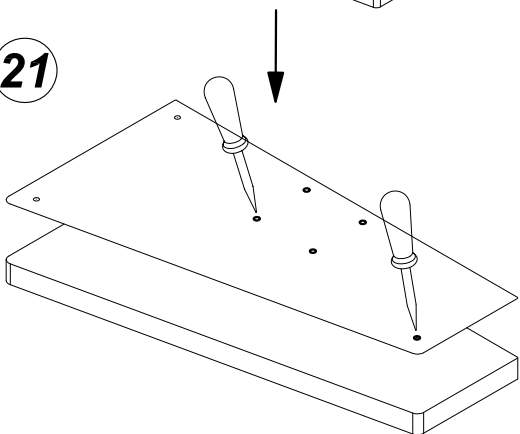

**22**

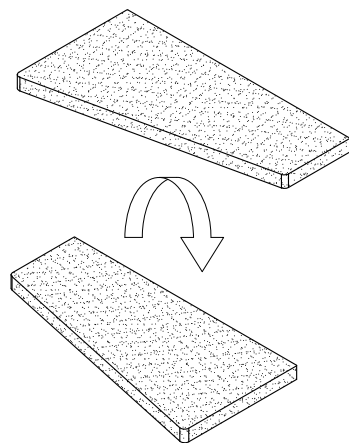

**23**

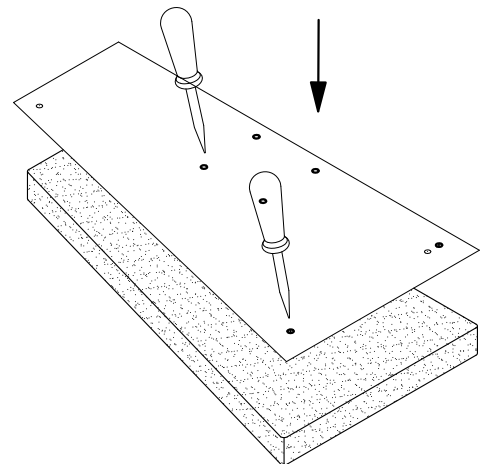

24

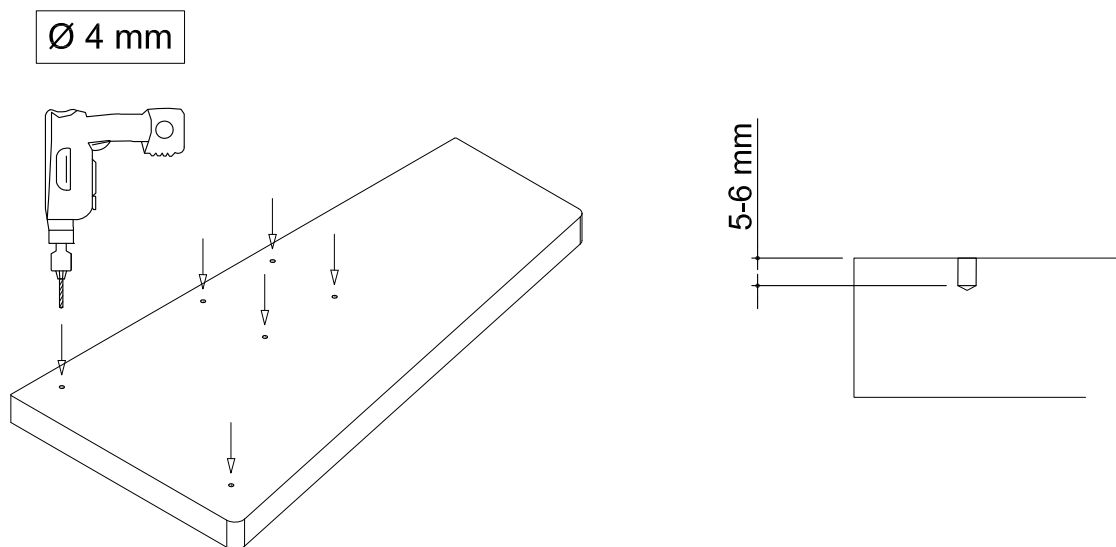

FISSAGGIO COLLEGAMENTO COLONNA-GRADINO / COLUMN-STEP CONNECTION FIXING / FIJACIÓN DE CONEXIÓN COLUMNA-PELDAÑO / FIXATION TUBE-MARCHE / VERBINDUNGSBEFESTIGUNG ZWISCHEN GELÄNDERSÄLE UND STUFE

25

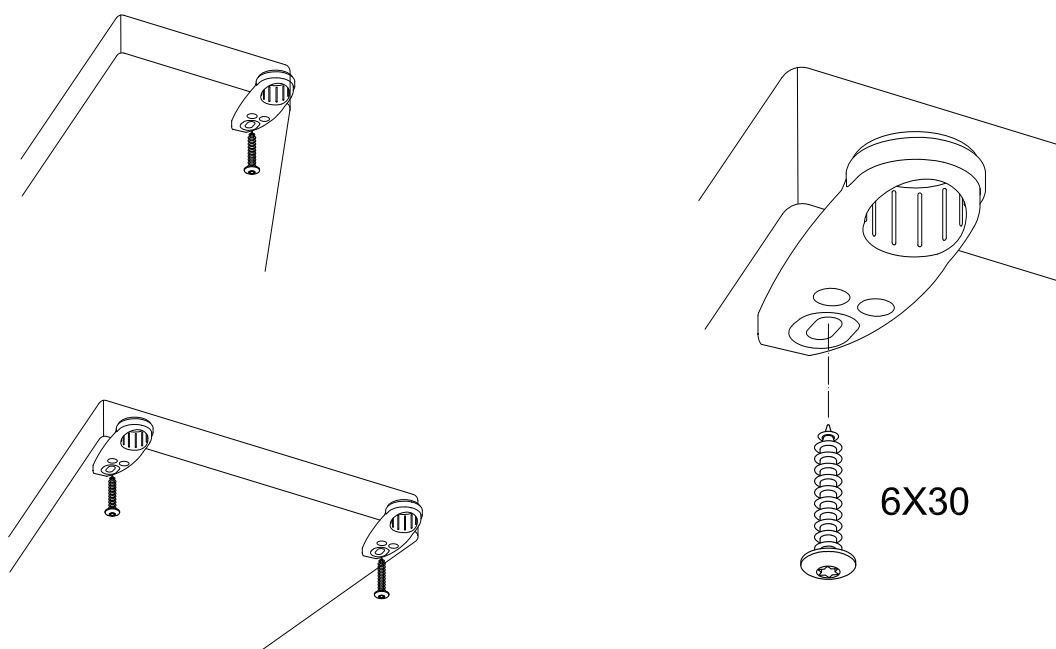



**FISSAGGIO GRADINI ALLE STRUTTURE / FIXING STEPS TO THE STRUCTURES / FIJACIÓN DE LOS PELDAÑOS A LAS ESTRUCTURAS / FIXATION MARCHES À LA STRUCTURE / VERBINDUNGSBEFESTIGUNG DER STUFEN AN DEN STRUKTUREN**

**26**

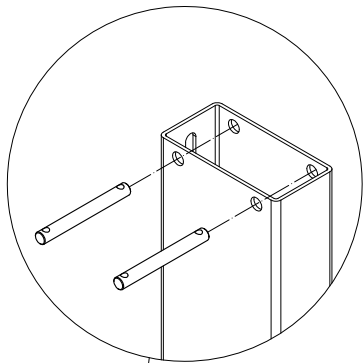

**27**

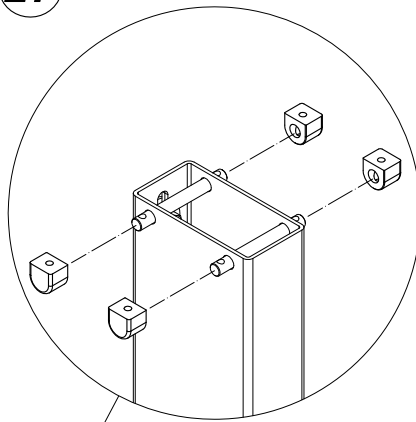

**28**

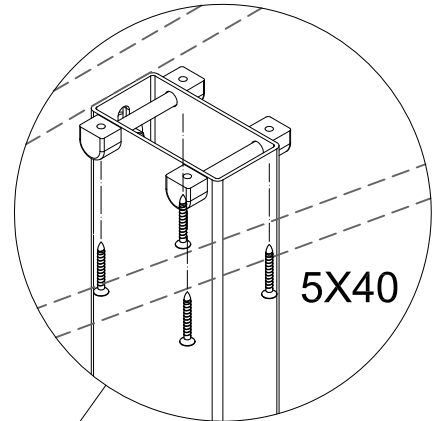

5X40

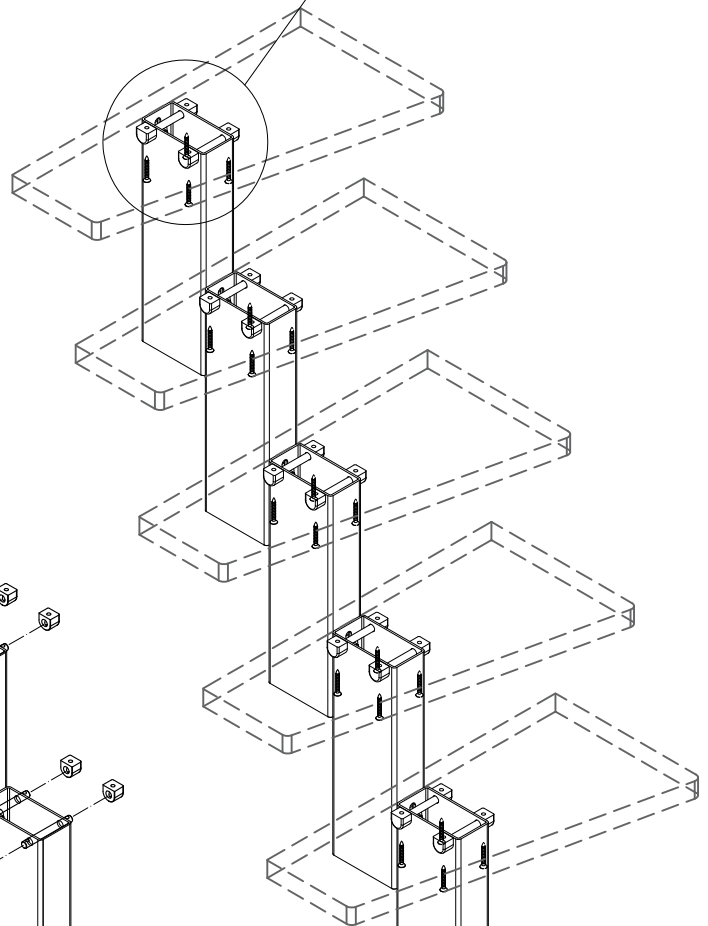
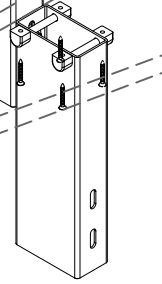
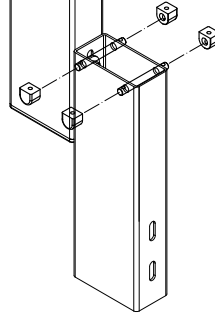
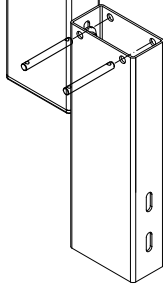
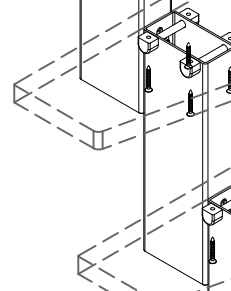
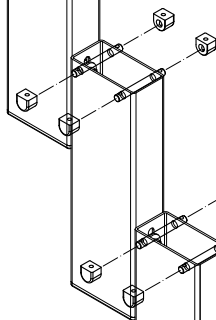
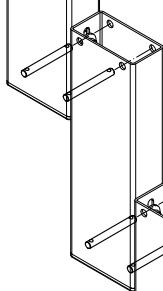
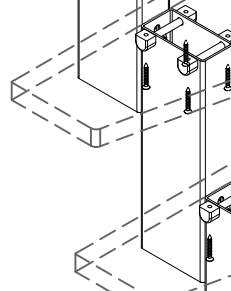
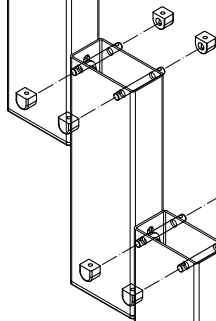
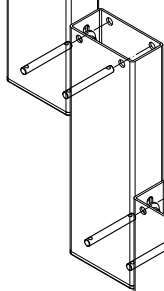
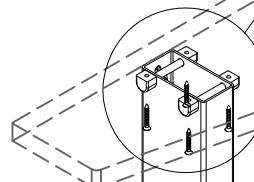
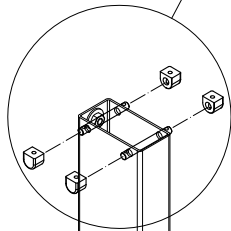
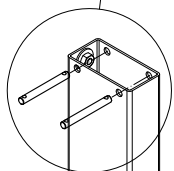

ASSEMBLAGGIO COLLEGAMENTI COLONNA-CORRIMANO / COLUMN-HANDRAIL CONNECTIONS ASSEMBLY /  
MONTAJE CONEXIONES COLUMNAS - PASAMANO / ASSEMBLAGE RACCORD COLONNE-MAIN COURANTE /  
VERBINDUNG ZWISCHEN GELÄNDERSÄULE UND HANDLAUF

29

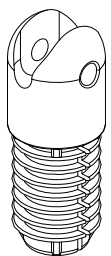

1

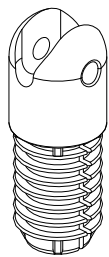

2

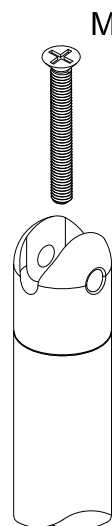
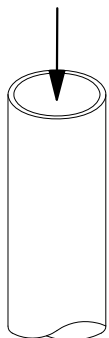

M6x50

3

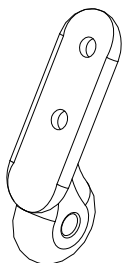

4

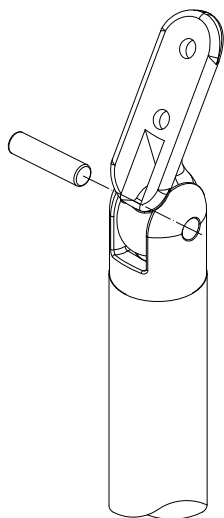
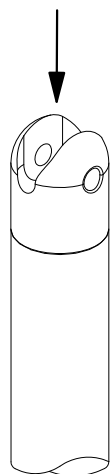

5

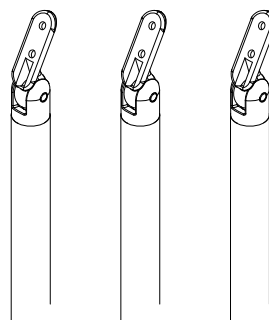
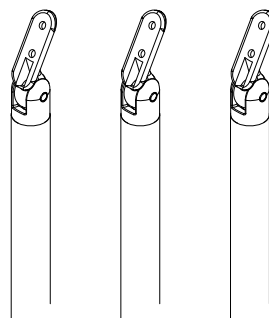

ASSEMBLAGGIO COLONNE / COLUMNS ASSEMBLY / MONTAJE COLUMNAS / ASSEMBLAGE COLONNES /  
GELÄNDERSÄULEN-MONTAGE

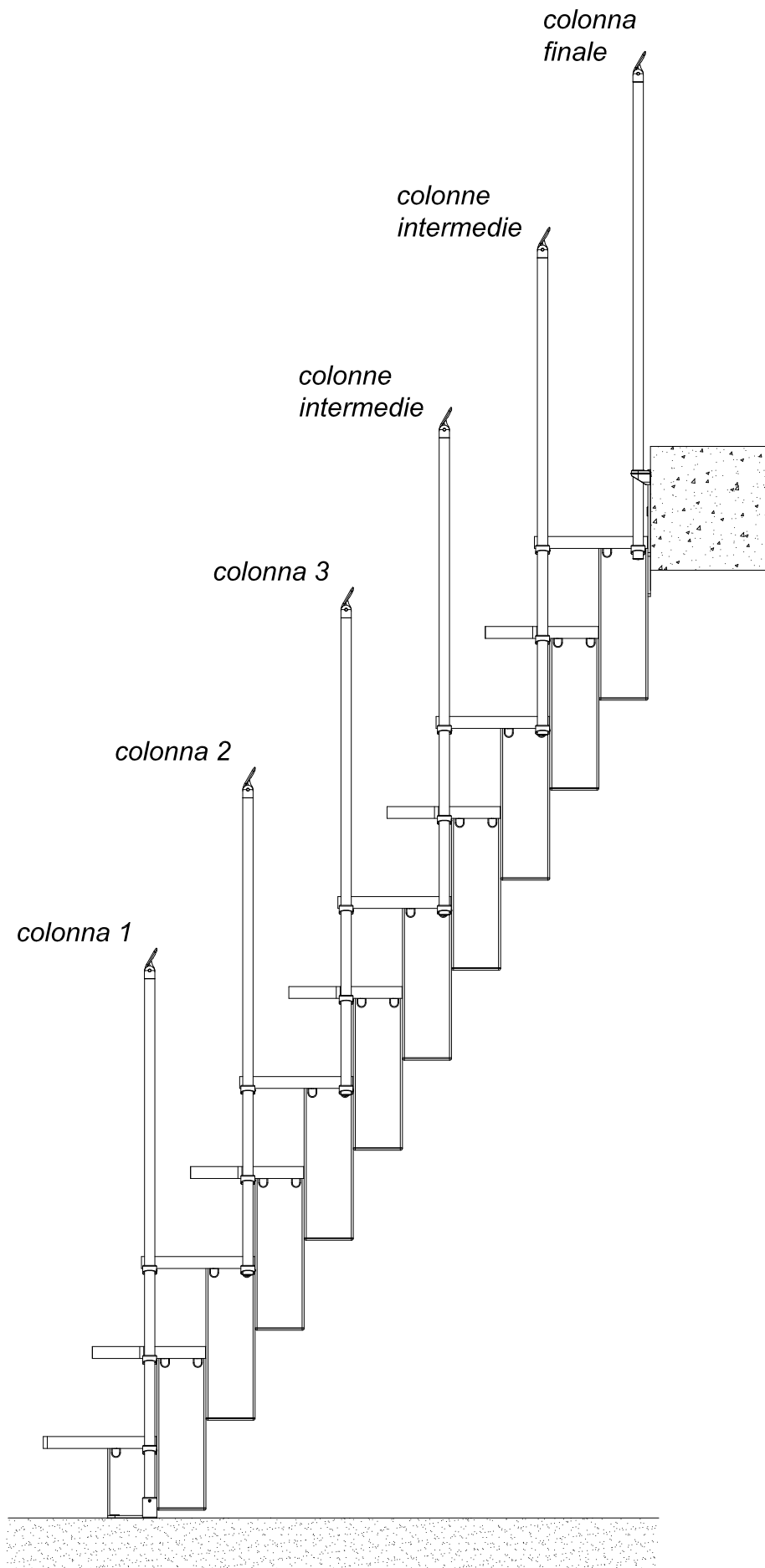

30

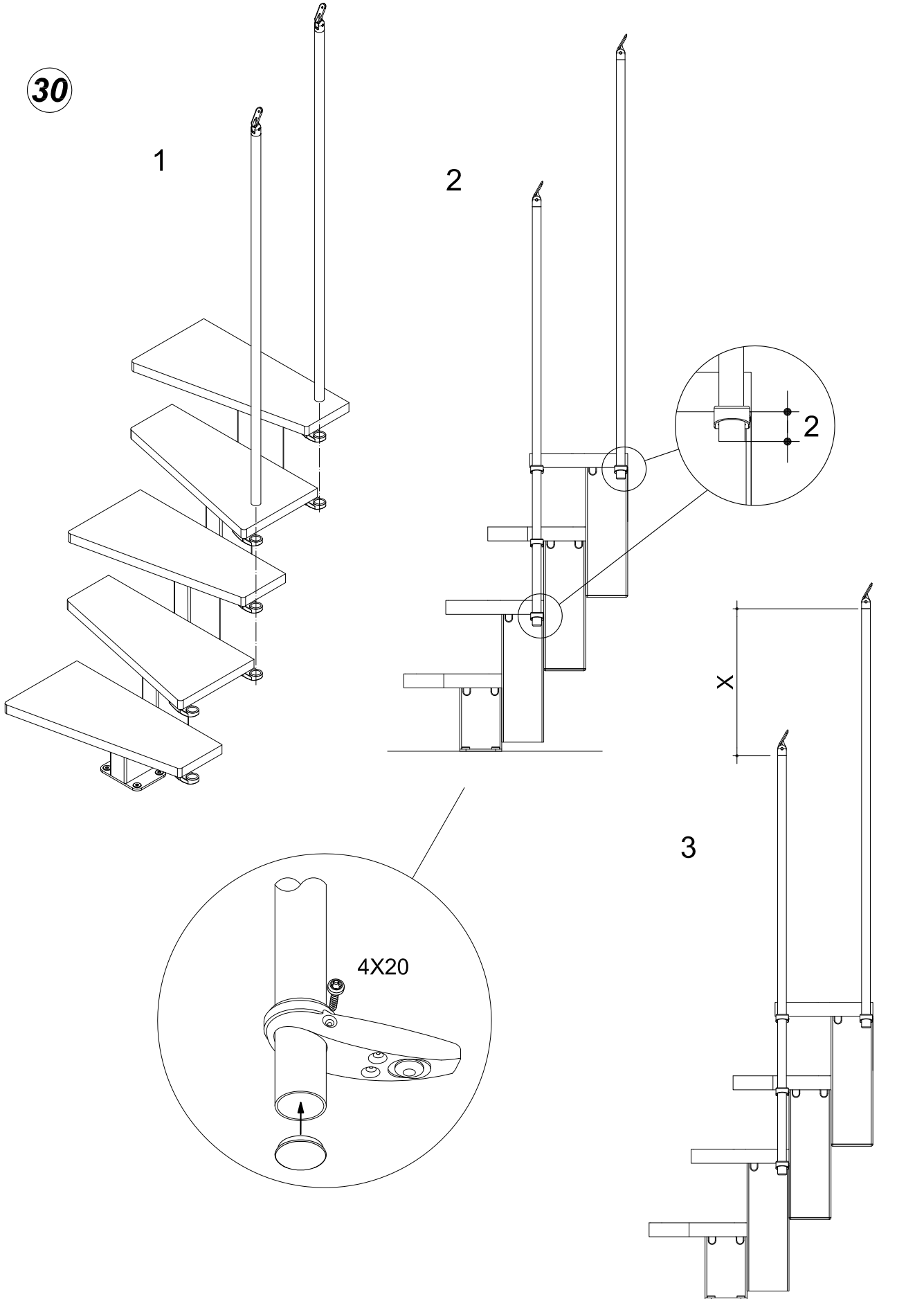

31

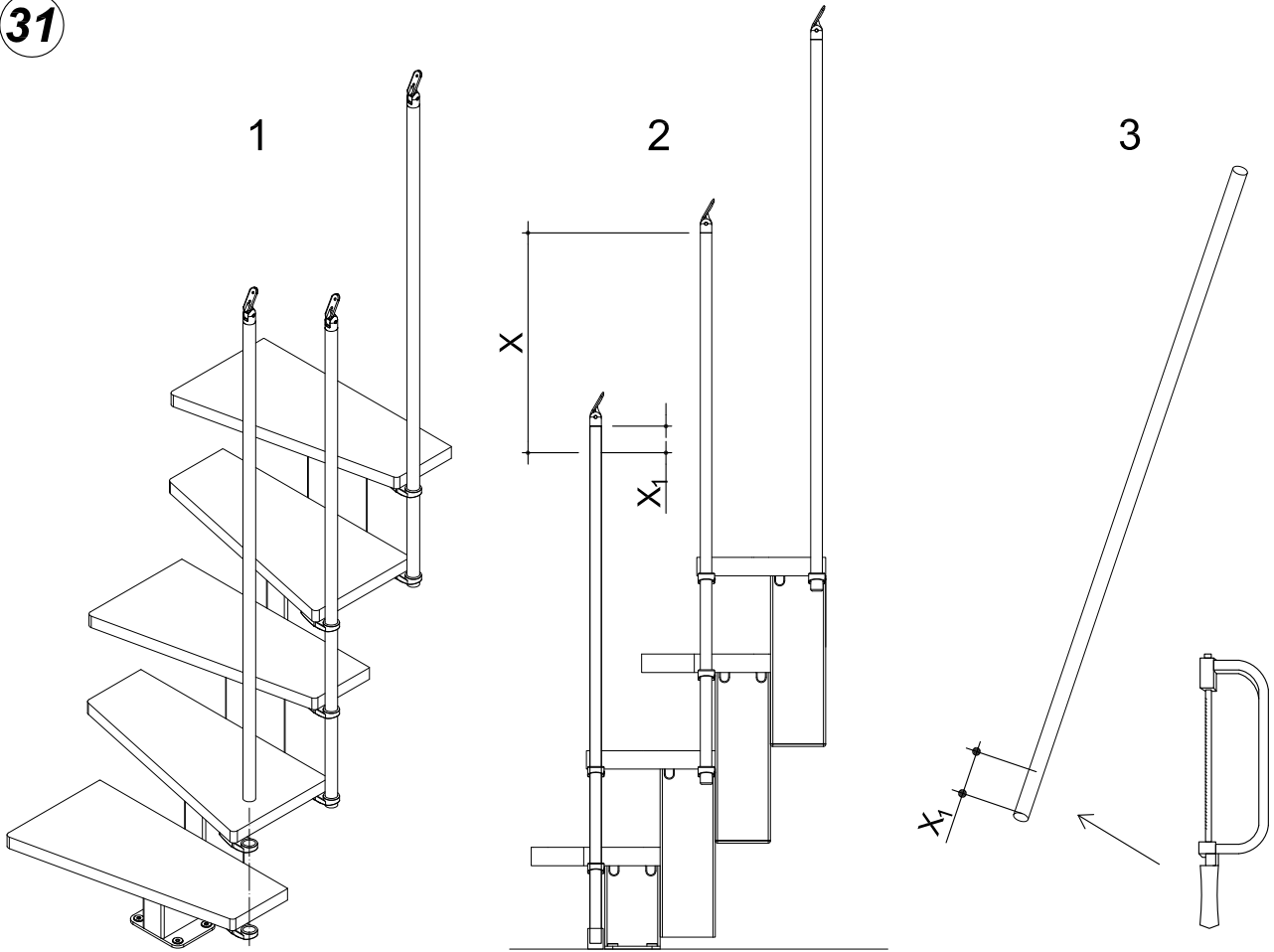

32

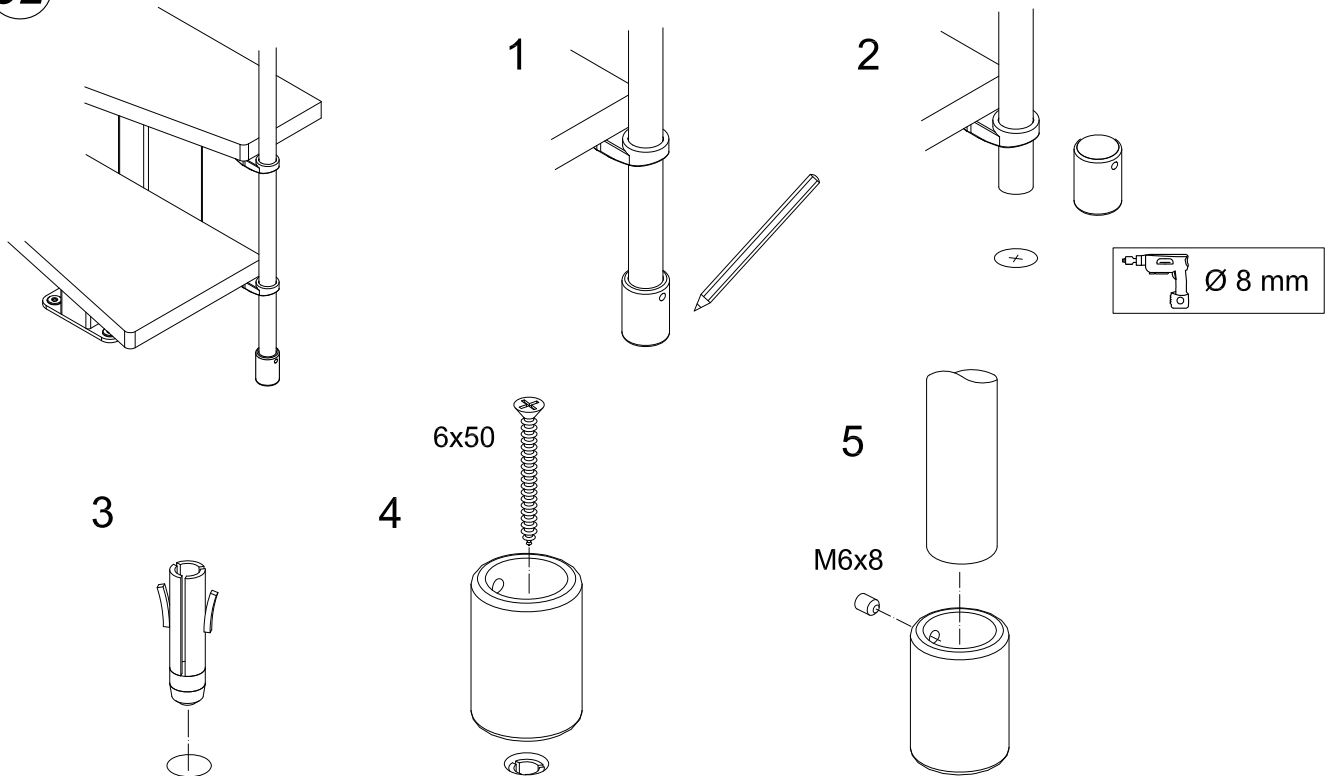

**ASSEMBLAGGIO COLONNE: colonne intermedie / COLUMN ASSEMBLY: intermediate columns / MONTAJE COLUMNAS: columnas intermedias / ASSEMBLAGE DE COLONNES: colonnes intermédiaires / GELÄNDERSÄULEN-MONTAGE: Von den Zwischensäulen**

**33**

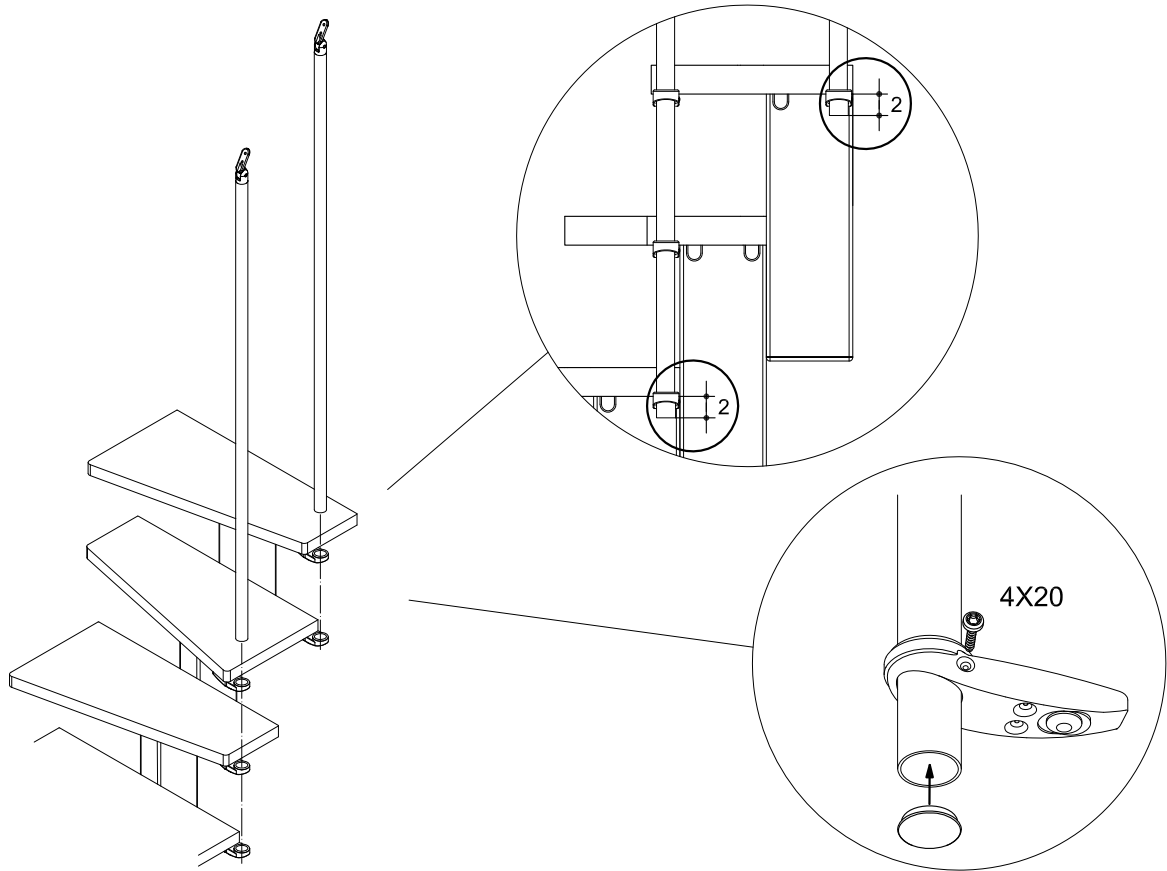

**ASSEMBLAGGIO COLONNE: colonna finale / COLUMN ASSEMBLY: final column / MONTAJE COLUMNAS: columna final / ASSEMBLAGE DE COLONNES: dernière colonne / GELÄNDERSÄULEN-MONTAGE: Von der Endsäule**

**34**

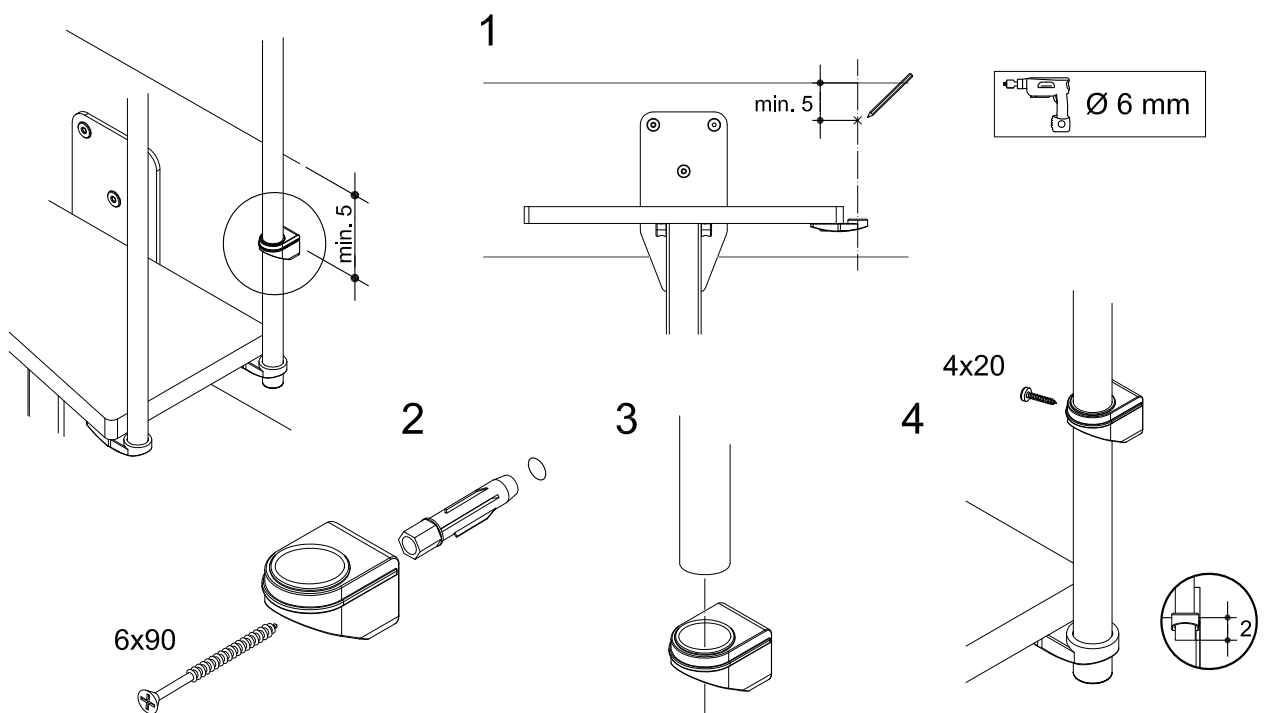

35

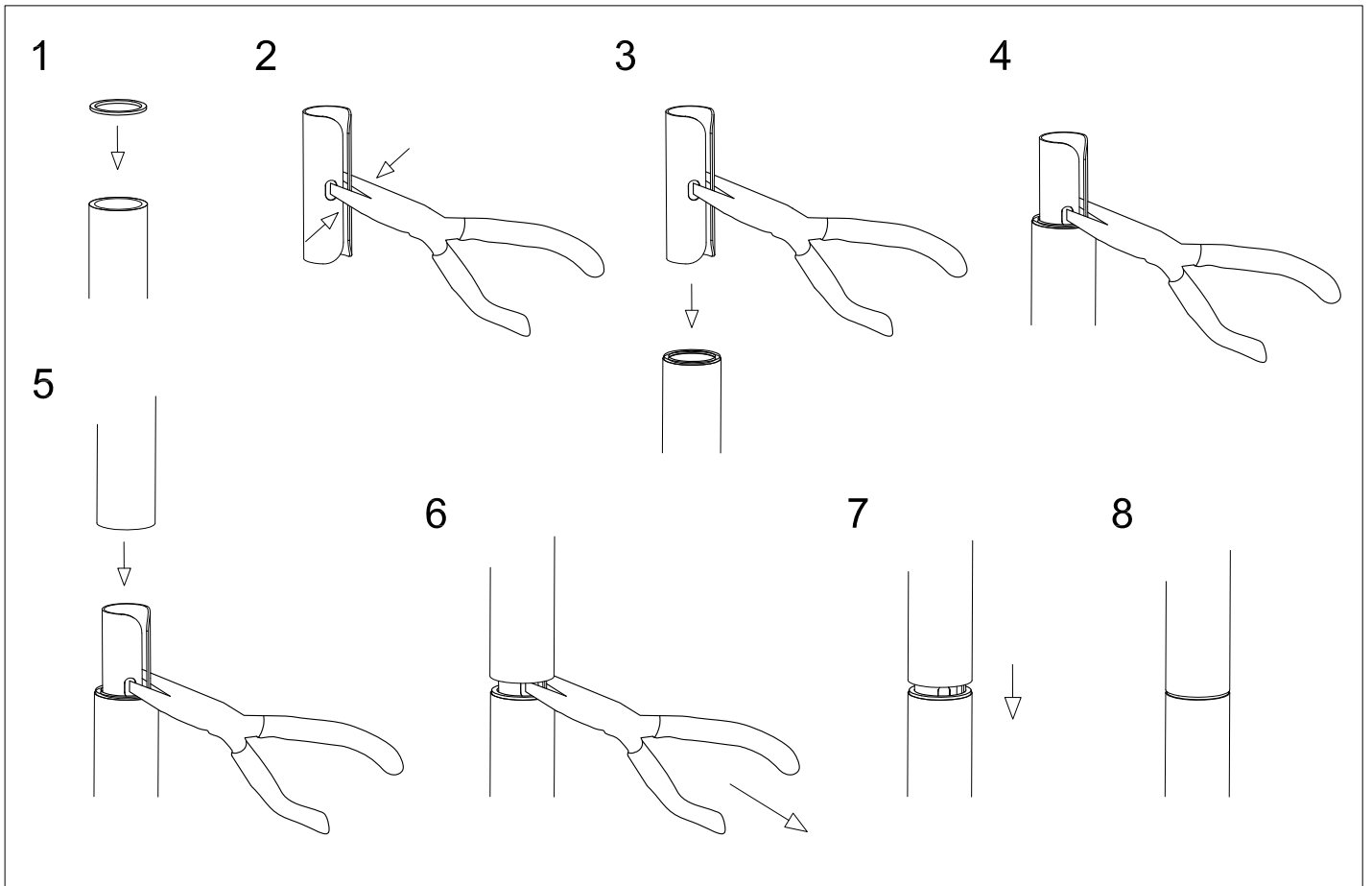
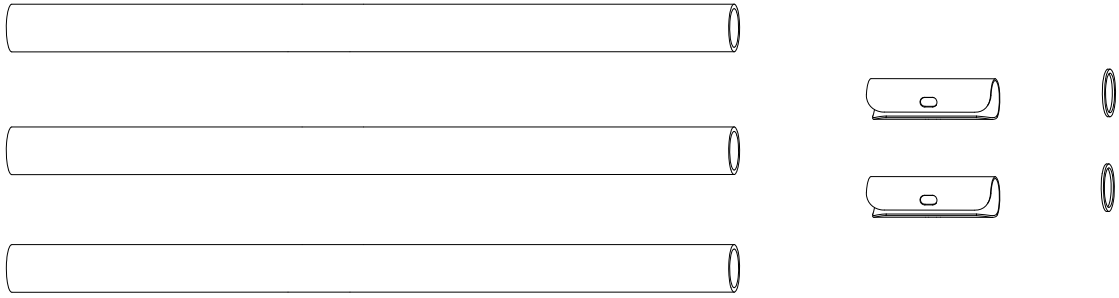

x 2

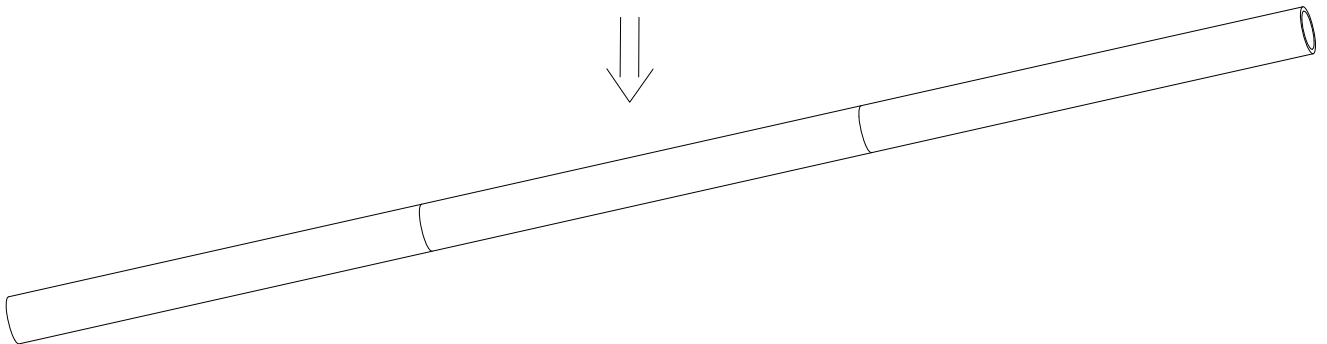

36

